

marathon®

WAUSAU, WISCONSIN, USA



RATINGS & SPECIFICATIONS GUIDE 50 HERTZ AND SPECIALTY GENERATORS

JAN 2026 | CATALOG EUROPE, MIDDLE EAST, AFRICA

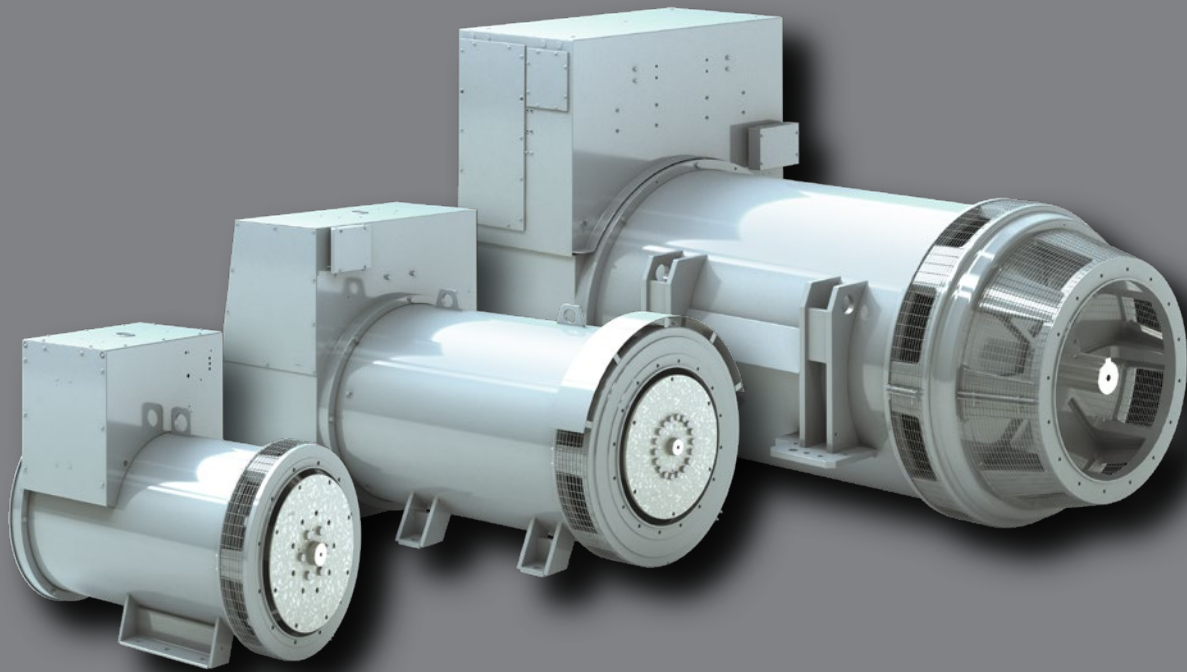

marathon®

The Marathon® Generator is a top performer in every respect: offering powerful performance, reliable power generation, and easy installation for prime power and emergency standby applications from 5 kVA to 4000 kVA.

The Marathon Generator brand provides an emphasis on custom and quality-manufactured solutions that provide reliability to customers. Marathon Generator's products are backed by an experienced customer service and technical support staff that are ready and available to support customer needs. Generators are manufactured and inventoried worldwide to meet the needs of our global customer base.

Marathon Generators ... for the long run

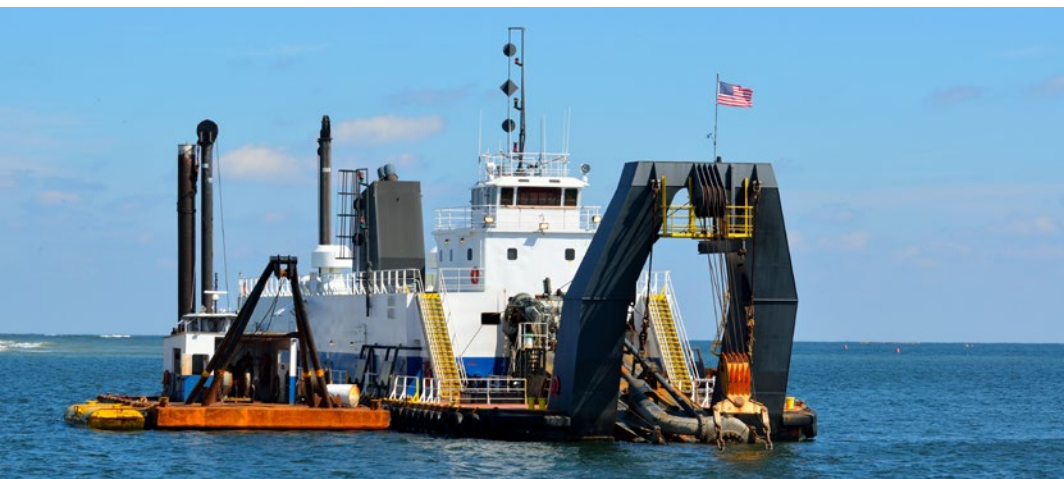

MARINE & HARSH DUTY

These rugged machines are built to withstand the most punishing environments – from hot, arid, dusty mining operations to humid, salt-laden sea air. With reinforced windings, fully encapsulated exciter stators and heavy-duty rectifier assemblies, Marathon's Mariner and Harsh Duty family of alternators deliver low-maintenance reliability.

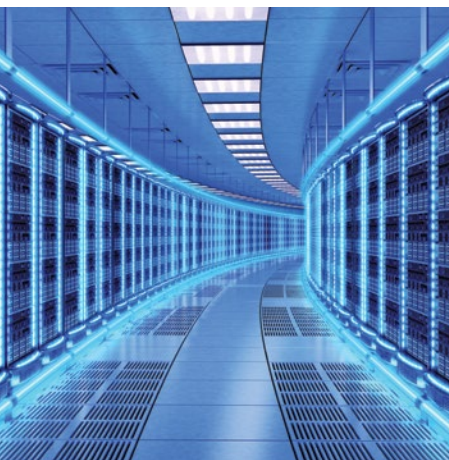

DATA CENTERS

When mission critical loads are on the line data centers around the world have grown to rely on Marathon® generators as the most trusted, most reliable option when it comes to efficient operation, long life, proven transient performance and guaranteed uptime.

CUSTOM DESIGNS

Highly engineered products designed specifically to your needs.

www.marathonelectric.com



CONSTRUCTION

Our light weight, compact design make our Pancake generators a powerful, economical power source for mobile lighting on construction jobsites.



IRRIGATION

Marathon offers generator packages specifically engineered for irrigation applications.

TABLE OF CONTENTS

RATINGS

MAGNAPLUS®, MAGNAMAX®, DATAMAX® GENERATORS

Three-phase, 190 Volts - 440 Volts	4-13
Three-phase, 3300 Volts - 6600 Volts	14
Three-phase, 10000 Volts - 11000 Volts	15
Single-phase, 110 Volts - 220 Volts	16-17
6-pole, 1000 rpm generators	18

SPECIALTY GENERATORS

Mariner® heavy duty generators	2
Harsh Duty® industrial generators	3

MODIFICATION SECTION

Generators, voltage regulators, accessories, testing & general notes	19-20
----------------------------------------------------------------------------------------------------	-------

TECHNICAL INFORMATION

Standard SAE dimensions	21
Dimensions, drawings, and weights	22-26
Environmental and special application considerations	27
Connection diagrams	28-29
Automatic voltage regulator features	30
Formulas	31
Warnings and cautions	32
Resale of goods and freight policy	3

50 Hertz 4-Pole Three Phase Generators

1500 RPM
Class H Insulation
0.8 Power Factor Lagging



FEATURES:

- Reinforced windings with multiple dip & bake cycles on main stator to handle high moisture salt-laden marine applications.
- Fully encapsulated exciter stator for maximum environmental protection.
- Heavy duty rectifier assembly designed to handle extreme voltage transient surges and over-current situations.
- Regulators: 280 through 430 frame sizes include **SE350E**; 570 frames include **DVR®2400** with PMG standard.

Base model	kVA Ratings @ 50°C Ambient, Cont.					
	220Y 95°C R/R	220Y 110°C R/R	380Y 95°C R/R	380Y 110°C R/R	400Y 95°C R/R	400Y 110°C R/R
12 Lead Reconnectable with Link Board as Standard						
361PSL3120	38	40	40	44	41	45
361PSL3121	43	45	50	53	50	52
361PSL3122	45	51	60	65	56	62
362PSL3124	65	75	75	80	73	81
362PSL3126	73	81	82	94	81	94
363PSL3127	90	101	100	113	100	113
431PSL6252	121	130	140	143	135	141
431PSL6254	143	151	160	166	160	165
431PSL6256	150	161	186	200	183	193
431PSL6258	183	195	200	210	200	210
432PSL6260	191	210	235	256	240	251
432PSL6262	245	260	256	270	256	271
433PSL6266	241	265	325	245	310	331
433PSL6270	285	310	355	375	350	368
12 Lead Reconnectable with Bus Bars as Standard						
572RSL6325	306	331	438	469	425	450
572RSL6327	356	363	450	475	463	494
572RSL6329	331	381	506	550	506	531
572RSL6331	431	469	513	563	525	563
573RSL6333	519	556	669	700	656	688
573RSL6335	469	513	663	738	669	706
574RSL6337	519	569	700	769	725	794

[General notes on page 20 may apply to this page.](#)
[See available modifications on pages 19](#)

4-Pole
Three Phase
Generators

50
Hertz

200Y or 400Y Volts

1500 RPM
Class H Insulation
0.8 Power Factor Lagging
40°C Ambient

HARSH DUTY®

FEATURES:

- Reinforced windings with multiple dip & bake cycles on main stator to handle dust-laden and/or harsh industrial applications.
- Fully Encapsulated exciter stator for maximum environmental protection.
- Heavy duty rectifier assembly designed to handle extreme voltage transient surges and over-current situations.
- **Regulators:** 280 through 430 frame sizes include **SE350E**; 570 frames include **DVR®2400** with PMG standard.

Base model	Ratings @ Designated Rise									
	Continuous						Stand by			
	B 80°C		F 105°C R/R		H 125°C R/R		F 130°C R/R		H 150°C R/R	
	kVA	kW	kVA	kW	kVA	kW	kVA	kW	kVA	kW
12 Lead Reconnectable with Link Board as Standard										
361PSL3120	39	31	44	36	48	38	48	38	51	41
361PSL3121	46	37	52	42	57	46	57	46	61	49
361PSL3122	53	43	63	50	68	54	68	54	75	60
362PSL3124	70	57	81	65	88	70	88	70	94	75
362PSL3126	78	63	94	75	100	80	100	80	110	88
363PSL3127	96	77	113	90	130	104	130	104	133	106
431PSL6252	123	98	141	113	150	120	153	122	160	128
431PSL6254	141	113	165	132	175	140	180	144	185	148
431PSL6256	161	129	193	154	206	165	210	168	220	176
431PSL6258	180	144	210	168	225	180	230	184	235	188
432PSL6260	211	169	251	201	270	216	275	220	285	228
432PSL6262	230	184	271	217	300	240	300	240	306	245
433PSL6266	270	216	331	265	360	288	370	296	385	308
433PSL6270	305	244	368	294	400	320	405	324	420	336
12 Lead Reconnectable with Bus Bars as Standard										
572RSL6325	381	305	450	360	475	380	488	390	506	405
572RSL6327	413	330	494	395	519	415	531	425	550	440
572RSL6329	438	350	531	425	569	455	581	465	600	480
572RSL6331	469	375	563	450	600	480	613	490	638	510
573RSL6333	594	475	688	550	725	580	738	590	763	610
573RSL6335	594	475	706	565	750	600	769	615	794	635
574RSL6337	669	535	794	635	850	680	863	690	894	715

[General notes on page 20 may apply to this page.](#)
[See available modifications on pages 19.](#)

RATINGS



190Y or 380Y Volts
220 or 110 Volts Delta

1500 RPM
Class H Insulation
40°C Ambient
0.8 Power Factor Lagging
Shunt (Non-PMG) Excitation
SE350E AVR

MAGNAPLUS® Standard Models

Base Model	Ratings @ Designated Rise									
	Continuous						Standby			
	B 80°C R/R		F 105°C R/R		H 125°C R/R		F 130°C R/R		H 150°C R/R	
	kVA	kW	kVA	kW	kVA	kW	kVA	kW	kVA	kW
12 Lead Reconnectable with Link Board as Standard										
281PSL1502	10	8	11.3	9	12	9.6	12	9.6	12.5	10
282PSL1504	15	12	16.3	13	17.5	14	17.5	14	18.8	15
282PSL1505	20	16	22.5	18	25	20	25	20	26.3	21
283PSL1506	22.5	18	25	20	26	21	26	21	28	23
283PSL1507	25	20	28	23	31	25	31	25	33	27
284PSL1508	31	25	36	29	40	32	40	32	42	34
284PSL1542	33	28	37	30	41	33	41	33	43	35
361PSL1600	38	30	44	35	45	36	45	36	50	40
361PSL1601	47	38	53	43	57	46	57	46	62	50
361PSL1602	57	46	65	52	70	56	70	56	75	60
362PSL1604	70	57	80	64	85	68	85	68	91	73
362PSL1606	81	65	94	75	100	80	100	80	110	88
363PSL1607	96	77	113	90	130	104	125	100	133	106
364PSL1609	125	100	156	125	169	135	169	135	180	144
431PSL6202	125	100	143	114	151	121	155	124	160	128
431PSL6204	144	115	166	133	176	141	180	144	185	148
431PSL6206	166	133	200	160	211	169	215	172	225	180
431PSL6208	180	144	210	168	225	180	230	184	235	188
432PSL6210	220	176	256	205	275	220	280	224	290	232
432PSL6212	230	184	270	216	300	240	300	240	303	242
433PSL6216	285	228	345	276	370	296	376	301	390	312
433PSL6220	315	252	375	300	400	320	410	328	423	338

[General notes on page 20 may apply to this page.](#)
[See available modifications on pages 19.](#)

RATINGS

**4-Pole
Three Phase
Generators**

**50
Hertz**

**190Y or 380Y Volts
220 or 110 Volts Delta
380Y Volts**

**1500 RPM
Class H Insulation
40°C Ambient
0.8 Power Factor Lagging
Includes PMG Excitation**

Regulator: Includes **DVR@2400**, except 572-574 frame RSL models which include **PM500**.

MAGNAMAX[®] Standard Models

Base Model	Ratings @ Designated Rise									
	Continuous						Standby			
	B 80°C R/R		F 105°C R/R		H 125°C R/R		F 130°C R/R		H 150°C R/R	
	kVA	kW	kVA	kW	kVA	kW	kVA	kW	kVA	kW
Random Wound Coil Designs, 12 Lead Reconnectable with Bus Bars Standard, 190/380Y										
572RSL6425	406	325	469	375	500	400	500	400	506	405
572RSL6427	419	335	475	380	500	400	513	410	544	435
572RSL6429	475	380	550	440	588	470	594	475	600	480
572RSL6431	500	400	563	450	600	480	613	490	644	515
573RSL6433	613	490	700	560	750	600	756	605	775	620
573RSL6435	625	500	738	590	781	625	800	640	819	655
574RSL6437	675	540	769	615	819	655	831	665	888	710
Random Wound Coil Designs, 4 Bars, 380Y Only										
574RSL6438	731	585	831	665	888	710	900	720	956	765
575RSL4044	806	645	963	770	1031	825	1056	845	1138	910
740RSL4046	969	775	1125	900	1200	960	1219	975	1300	1040
742RSL4048	1050	840	1181	945	1250	1000	1263	1010	1338	1070
742RSL4050	1188	950	1363	1090	1463	1170	1500	1200	1563	1250
743RSL4052	1388	1110	1650	1320	1775	1420	1775	1420	1850	1480
744RSL4054	1500	1200	1750	1400	1875	1500	1913	1530	1988	1590
744RSL4056	1763	1410	2063	1650	2200	1760	2238	1790	2400	1920
744RSL4058	1380	1725	1610	2013	1720	2150	1750	2188	1870	2338

DATAMAX[™] Standard Models

All 860 & 1000 frame generators have 4 bus bars, with the capability of differential protection.

Base Model	Ratings @ Designated Rise									
	Continuous						Standby			
	B 80°C R/R		F 105°C R/R		H 125°C R/R		F 130°C R/R		H 150°C R/R	
	kVA	kW	kVA	kW	kVA	kW	kVA	kW	kVA	kW
Random Wound Coil Designs, 6 Lead, 380Y Only										
861RSL13002	2000	1600	2275	1820	2500	2000	2500	2000	2625	2100
862RSL13004	2175	1740	2475	1980	2700	2160	2700	2160	2850	2280
862RSL13006	2376	1900	2688	2150	2938	2350	2938	2350	3125	2500
1020RDL1310	2700	2160	3038	2430	3375	2700	3400	2720	3550	2840
1020RDL1312	2850	2280	3188	2550	3525	2820	3563	2850	3700	2960
1030RDL1314	3125	2500	3500	2800	3875	3100	3938	3150	4063	3250

[General notes on page 20 may apply to this page.](#)
[See available modifications on pages 19.](#)

RATINGS



200Y or 400Y Volts
230 or 115 Volts Delta

1500 RPM
Class H Insulation
40°C Ambient
0.8 Power Factor Lagging
Shunt (Non-PMG) Excitation
SE350E AVR

MAGNAPLUS® Standard Models

Base Model	Ratings @ Designated Rise									
	Continuous						Standby			
	B 80°C R/R		F 105°C R/R		H 125°C R/R		F 130°C R/R		H 150°C R/R	
	kVA	kW	kVA	kW	kVA	kW	kVA	kW	kVA	kW
12 Lead Reconnectable with Link Board as Standard										
282PSL1502	10.3	8.2	11.7	9.3	12.3	9.8	12.3	9.8	12.9	10.3
282PSL1504	15	12	16.3	13	17.5	14	17.5	14	18.8	15
282PSL1505	19.6	15.7	21.8	17.4	23.9	19.1	23.9	19.1	25	20
283PSL1506	21.9	17.5	25	20	26	21	26	21	28	23
283PSL1507	25	20	28	22	30	24	30	24	33	26
284PSL1508	30	24	33	27	37	30	37	30	40	32
284PSL1542	33	27	37	30	41	33	41	33	45	36
361PSL1600	39	31	44	36	48	38	48	38	51	41
361PSL1601	46	37	52	42	57	46	57	46	61	49
361PSL1602	53	43	62	50	67	54	68	54	75	60
362PSL1604	70	57	81	65	88	70	88	70	94	75
362PSL1606	78	63	93	75	100	80	100	80	110	88
363PSL1607	96	77	113	90	130	104	130	104	133	106
364PSL1609	125	100	156	125	169	135	169	135	180	144
431PSL6202	123	98	141	113	150	120	153	122	160	128
431PSL6204	141	113	165	132	175	140	180	144	185	148
431PSL6206	161	129	193	154	206	165	210	168	220	176
431PSL6208	180	144	210	168	225	180	230	184	235	188
432PSL6210	211	169	251	201	270	216	275	220	285	228
432PSL6212	230	184	271	217	300	240	300	240	306	245
433PSL6216	270	216	331	265	360	288	370	296	385	308
433PSL6220	305	244	368	294	400	320	405	324	420	336

[General notes on page 20 may apply to this page.](#)
[See available modifications on pages 19.](#)

RATINGS

**4-Pole
Three Phase
Generators**

**50
Hertz**

**200Y or 400Y Volts
230 or 115 Volts Delta
400Y Volts**

**1500 RPM
Class H Insulation
40°C Ambient
0.8 Power Factor Lagging
Includes PMG Excitation**

Regulator: Includes DVR@2400, except 572-574 frame RSL models which include PM500.

MAGNAMAX® Standard Models

Base Model	Ratings @ Designated Rise									
	Continuous						Standby			
	B 80°C R/R		F 105°C R/R		H 125°C R/R		F 130°C R/R		H 150°C R/R	
	kVA	kW	kVA	kW	kVA	kW	kVA	kW	kVA	kW
Random Wound Coil Designs, 12 Lead Reconnectable with Bus Bars Standard 200Y/400Y										
572RSL6425	381	305	450	360	475	380	488	390	506	405
572RSL6427	413	330	494	395	519	415	531	425	550	440
572RSL6429	438	350	531	425	569	455	581	465	600	480
572RSL6431	469	375	563	450	600	480	613	490	638	510
573RSL6433	594	475	688	550	725	580	738	590	763	610
573RSL6435	594	475	706	565	750	600	769	615	794	635
574RSL6437	669	535	794	635	850	680	863	690	894	715
Random Wound Coil Designs, 4 Bars, 400Y Only										
574RSL6438	713	570	850	680	913	730	931	745	963	770
575RSL4044	788	630	963	770	1038	830	1063	850	1144	915
740RSL4046	988	790	1150	920	1225	980	1250	1000	1338	1070
742RSL4048	1000	800	1200	960	1288	1030	1288	1030	1363	1090
742RSL4050	1238	990	1450	1160	1550	1240	1563	1250	1638	1310
743RSL4052	1275	1020	1550	1240	1688	1350	1688	1350	1813	1450
744RSL4054	1513	1210	1788	1430	1925	1540	1925	1540	2038	1630
744RSL4056	1763	1410	2113	1690	2288	1830	2338	1870	2450	1960
744RSL4058	1430	1488	1670	2088	1790	2338	1820	2775	1950	2438

DATAMAX™ Standard Models

All 860 & 1000 frame generators have 4 bus bars, with the capability of differential protection.

Base Model	Ratings @ Designated Rise									
	Continuous						Stand by			
	B 80°C R/R		F 105°C R/R		H 125°C R/R		F 130°C R/R		H 150°C R/R	
	kVA	kW	kVA	kW	kVA	kW	kVA	kW	kVA	kW
Random Wound Coil Designs, 6 Lead, 400Y Only										
861RSL13002	2125	1700	2500	2000	2625	2100	2625	2100	2750	2200
862RSL13004	2250	1800	2625	2100	2800	2240	2800	2240	3000	2400
862RSL13006	2438	1950	2750	2200	3000	2400	3000	2400	3188	2550
1020RDL1310	2625	2100	3125	2500	3375	2700	3375	2700	3625	2900
1020RDL1312	3063	2450	3438	2750	3750	3000	3750	3000	4000	3200
1030RDL1314	3125	2500	3600	2880	4000	3200	4000	3200	4250	3400

[General notes on page 20 may apply to this page.](#)
[See available modifications on pages 19.](#)



208Y or 415Y Volts
240 or 120 Volts Delta

1500 RPM
Class H Insulation
40°C Ambient
0.8 Power Factor Lagging
Shunt (Non-PMG) Excitation
SE350E AVR

MAGNAPLUS Standard Models

Base Model	Ratings @ Designated Rise									
	Continuous						Standby			
	B 80°C R/R		F 105°C R/R		H 125°C R/R		F 130°C R/R		H 150°C R/R	
	kVA	kW	kVA	kW	kVA	kW	kVA	kW	kVA	kW
12 Lead Reconnectable with Link Board as Standard										
282PSL1502	10.8	8.6	12	9.6	12.5	10	12.5	10	13.1	10.5
282PSL1504	15	12	16.3	13	17.5	14	17.5	14	18.8	15
282PSL1505	18.8	15	21.3	17	23.1	18.5	23.1	18.5	25	20
283PSL1506	20	16	22	18	25	20	25	20	27	22
283PSL1507	25	20	27	22	30	24	30	24	32	26
284PSL1508	27	22	31	25	35	28	35	28	37	30
284PSL1542	32	26	36	29	40	32	40	32	42	34
361PSL1600	40	32	45	36	50	40	50	40	53	42
361PSL1601	45	36	50	40	56	45	56	45	60	48
361PSL1602	50	40	60	48	65	52	65	52	73	58
362PSL1604	70	57	81	65	90	72	90	72	96	77
362PSL1606	75	60	90	72	100	80	100	80	110	88
363PSL1607	96	77	113	90	130	104	130	104	133	106
364PSL1609	125	100	150	120	163	130	163	130	175	140
431PSL6202	118	94	140	112	150	120	150	120	155	124
431PSL6204	140	112	165	132	175	140	176	141	183	146
431PSL6206	153	122	185	148	200	160	205	164	211	169
431PSL6208	175	140	206	165	225	180	225	180	235	188
432PSL6210	196	157	240	192	260	208	265	212	275	220
432PSL6212	230	184	270	216	300	240	300	240	310	248
433PSL6216	251	201	320	256	350	280	360	288	375	300
433PSL6220	286	229	355	284	400	320	400	320	410	328

[General notes on page 20 may apply to this page.](#)
[See available modifications on pages 19.](#)

**4-Pole
Three Phase
Generators**

**50
Hertz**

**208Y or 415Y Volts
240 or 120 Volts Delta
415Y Volts**

**1500 RPM
Class H Insulation
40°C Ambient
0.8 Power Factor Lagging
Includes PMG Excitation**

Regulator: Includes DVR@2400, except 572-574 frame RSL models which include PM500.

MAGNAMAX® Standard Models

Base Model	Ratings @ Designated Rise									
	Continuous						Standby			
	B 80°C R/R		F 105°C R/R		H 125°C R/R		F 130°C R/R		H 150°C R/R	
	kVA	kW	kVA	kW	kVA	kW	kVA	kW	kVA	kW
Random Wound Coil, 12 Lead Reconnectable with Bus Bars Standard, 208Y/415Y										
572RSL6425	344	275	413	330	444	355	456	365	475	380
572RSL6427	388	310	469	375	500	400	513	410	531	425
572RSL6429	406	325	500	400	531	425	544	435	563	450
572RSL6431	444	355	550	440	581	465	600	480	625	500
573RSL6433	550	440	650	520	700	560	713	570	738	590
573RSL6435	538	430	669	535	713	570	731	585	756	605
574RSL6437	600	480	731	585	788	630	800	640	838	670
Random Wound Coil Designs, 4 Bars, 415Y Only										
574RSL6438	688	550	825	660	888	710	906	725	938	750
575RSL4044	796	615	963	770	1013	810	1025	820	1056	845
740RSL4046	919	735	1106	885	1188	950	1219	975	1275	1020
742RSL4048	931	745	1131	905	1219	975	1219	975	1300	1040
742RSL4050	1188	950	1438	1150	1538	1230	1538	1230	1638	1310
743RSL4052	1169	935	1500	1200	1600	1280	1600	1280	1725	1380
744RSL4054	1438	1150	1725	1380	1875	1500	1875	1500	2013	1610
744RSL4058	1310	1638	1630	2038	1780	2225	1830	2288	1920	2400

DATAMAX™

Standard Models

All 860 & 1000 frame generators have 4 bus bars, with the capability of differential protection.

Base Model	Ratings @ Designated Rise									
	Continuous						Stand by			
	B 80°C R/R		F 105°C R/R		H 125°C R/R		F 130°C R/R		H 150°C R/R	
	kVA	kW	kVA	kW	kVA	kW	kVA	kW	kVA	kW
Random Wound Coil Designs, 6 Lead, 415Y Only										
861RSL13002	2000	1600	2275	1820	2500	2000	2500	2000	2625	2100
862RSL13004	2200	1760	2500	2000	2725	2180	2725	2180	2863	2290
862RSL13006	2375	1900	2656	2125	2900	2320	2900	2320	3075	2460
1020RDL1310	2680	2144	3015	2412	3350	2680	3375	2700	3518	2814
1020RDL1312	3000	2400	3375	2700	3750	3000	3788	3030	3938	3150
1030RDL1314	3125	2500	3500	2800	3875	3100	3913	3130	4063	3250

[General notes on page 20 may apply to this page.](#)
[See available modifications on pages 19.](#)

50 Hertz **4-Pole Three Phase Generators**

220Y or 440Y Volts

1500 RPM
Class H Insulation
40°C Ambient
0.8 Power Factor Lagging
Shunt (Non-PMG) Excitation
SE350E AVR

MAGNAPLUS® Standard Models

Base Model	Ratings @ Designated Rise									
	Continuous						Standby			
	B 80°C R/R		F 105°C R/R		H 125°C R/R		F 130°C R/R		H 150°C R/R	
	kVA	kW	kVA	kW	kVA	kW	kVA	kW	kVA	kW
12 Lead Reconnectable with Link Board as Standard										
282PSL1502	8.6	6.9	9.6	7.7	10	8	10	8	10.5	8.4
282PSL1504	12	9.6	13	10.4	14	11.2	14	11.2	15	12
282PSL1505	15	12	17	13.6	18.5	14.8	18.5	14.8	20	16
283PSL1506	16	12.8	18	14.4	20	16	20	16	22	17.6
283PSL1507	20	16	22	17.6	24	19.2	24	19.2	26	20
284PSL1508	21	16.8	25	20	27	22	27	22	30	24
361PSL1600	38	30	41	32	45	36	45	36	47	36
361PSL1601	40	32	45	36	51	41	51	41	54	43
361PSL1602	43	35	51	41	56	45	56	45	60	48
362PSL1604	63	50	75	60	81	65	81	65	88	77
362PSL1606	69	55	81	65	90	72	90	72	100	80
363PSL1607	86	69	101	81	113	90	113	90	119	95
364PSL1609	108	86	130	104	141	113	141	113	150	120
431PSL6202	108	86	130	104	140	112	141	113	150	120
431PSL6204	125	100	151	121	163	130	166	133	173	138
431PSL6206	128	102	161	129	176	141	181	145	190	152
431PSL6208	160	128	195	156	210	168	215	172	225	180
432PSL6210	161	129	210	168	230	184	235	188	250	200
432PSL6212	213	170	260	208	280	224	286	229	300	240
433PSL6216	195	156	265	212	300	240	310	248	326	261
433PSL6220	236	189	310	248	343	274	343	274	371	297

General notes on page 20 may apply to this page.
See available modifications on pages 19.

RATINGS

**4-Pole
Three Phase
Generators**

**50
Hertz**

**220Y or 440Y Volts
440Y Volts**

**1500 RPM
Class H Insulation
40°C Ambient
0.8 Power Factor Lagging
Includes PMG Excitation**

Regulator: Includes **DVR@2400**, except 572-574 frame RSL models which include **PM500**.

MAGNAMAX[®] Standard Models

Base Model	Ratings @ Designated Rise									
	Continuous						Standby			
	B 80°C R/R		F 105°C R/R		H 125°C R/R		F 130°C R/R		H 150°C R/R	
	kVA	kW	kVA	kW	kVA	kW	kVA	kW	kVA	kW
Random Wound Coil, 12 Lead Reconnectable with Bus Bars Standard, 220Y/440Y										
572RSL6425	256	205	331	265	363	290	375	300	394	315
572RSL6427	306	245	381	305	419	335	425	340	444	355
572RSL6429	296	215	363	290	406	325	419	335	444	355
572RSL6431	363	290	469	375	519	415	531	425	563	450
573RSL6433	450	360	556	445	606	485	625	500	656	525
573RSL6435	394	315	513	410	569	455	588	470	619	495
574RSL6437	438	350	569	455	631	505	650	520	688	550
Random Wound Coil Designs, 4 Bars, 440Y Only										
574RSL6438	581	465	725	580	794	635	813	650	850	680
575RSL4044	463	370	681	545	781	625	813	650	875	700
740RSL4046	694	555	913	730	1000	800	1038	830	1094	875
742RSL4048	731	585	938	750	1031	825	1031	825	1113	890
742RSL4050	1088	870	1350	1080	1463	1170	1463	1170	1563	1250
743RSL4052	806	645	1119	895	1263	1010	1263	1010	1388	1110
744RSL4054	988	790	1363	1090	1550	1240	1550	1240	1713	1370
744RSL4056	1146	917	1575	1260	1763	1410	1825	1460	1925	1540
744RSL4058	897	1121	1230	1538	1380	1725	1420	1775	1500	1875

[General notes on page 20 may apply to this page.](#)
[See available modifications on pages 19.](#)

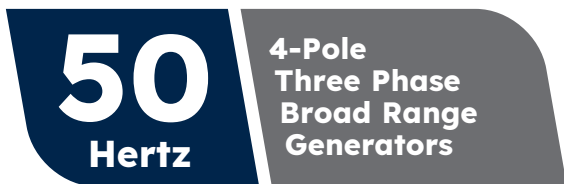

190Y-208Y or
380Y-415Y Volts

1500 RPM
Class H Insulation
40°C Ambient
0.8 Power Factor Lagging
Shunt (Non-PMG) Excitation
SE350E AVR

MAGNAPLUS® Standard Models

Base Model	Ratings @ Designated Rise									
	Continuous						Standby			
	B 80°C R/R		F 105°C R/R		H 125°C R/R		F 130°C R/R		H 150°C R/R	
	kVA	kW	kVA	kW	kVA	kW	kVA	kW	kVA	kW
12 Lead Reconnectable with Link Board as Standard										
282PSL1502	10	8	11.3	9	12	9.6	12	9.6	12.5	10
282PSL1504	15	12	16.3	13	17.5	14	17.5	14	18.8	15
282PSL1505	18.8	15	21.3	17	23.1	18.5	23.1	18.5	25	20
283PSL1506	20	16	22	18	25	20	25	20	27	22
283PSL1507	25	20	27	22	30	24	30	24	32	26
284PSL1508	27	22	31	25	35	28	35	28	37	30
284PSL1542	33	27	36	29	40	32	40	32	42	34
361PSL1600	38	30	44	35	45	36	45	36	50	40
361PSL1601	45	36	50	40	56	45	56	45	60	48
361PSL1602	50	40	60	48	65	52	65	52	73	58
362PSL1604	70	57	80	64	85	68	85	68	91	73
362PSL1606	75	60	90	72	100	80	100	80	110	88
363PSL1607	96	77	113	90	130	104	125	100	133	106
364PSL1609	125	100	156	125	169	135	169	135	180	144
431PSL6202	118	94	140	112	150	120	150	120	155	124
431PSL6204	140	112	165	132	175	140	176	141	183	146
431PSL6206	153	122	185	148	200	160	205	164	211	169
431PSL6208	175	140	206	165	225	180	230	184	235	188
432PSL6210	196	157	240	192	260	208	265	212	275	220
432PSL6212	230	184	270	216	300	240	300	240	303	242
433PSL6216	251	201	320	256	350	280	360	288	375	300
433PSL6220	286	229	355	284	400	320	400	320	410	328

General notes on page 20 may apply to this page.
See available modifications on pages 19.

MAGNAMAX® Standard Models

Base Model	Ratings @ Designated Rise									
	Continuous						Standby			
	B 80°C R/R		F 105°C R/R		H 125°C R/R		F 130°C R/R		H 150°C R/R	
	kVA	kW	kVA	kW	kVA	kW	kVA	kW	kVA	kW
Random Wound Coil Designs ,12 Lead Reconnectable with Bus Bars Standard.										
572RSL6425	344	275	413	330	444	355	456	365	475	380
572RSL6427	388	310	469	375	500	400	513	410	531	425
572RSL6429	406	325	500	400	531	425	544	435	563	450
572RSL6431	444	355	550	440	581	465	600	480	625	500
573RSL6433	550	440	650	520	700	560	713	570	738	590
573RSL6435	538	430	669	535	713	570	731	585	756	605
574RSL6437	600	480	731	585	788	630	800	640	838	670

General notes on page 20 may apply to this page.
See available modifications on page 19.

RATINGS

4-Pole
Three Phase
Generators

50
Hertz

1500 RPM
40°C Ambient
0.8 Power Factor Lagging
DVR®2400 AVR w/PMG Excitation

DATAMAX™

FEATURES:

- Low Reactance Designs (*Contact factory for other custom reactance value designs)
- Other voltage designs available (Contact factory for details)

400Y/230 Volts

All 860 & 1000 frame generators have 4 bus bars, with the capability of differential protection.

Base Model	Ratings @ Designated Rise				
	Continous			Stand by	
	80°C	105°C	125°C	130°C	150°C
	kVA	kVA	kVA	kVA	kVA
4 Bars					
743RSL1352	1275	1550	1688	1688	1813
744RSL1354	1513	1788	1925	1925	2038
744RSL1356	1763	2113	2288	2338	2450
6 Lead, 4 Bus Bars					
861RSL13002	2125	2500	2625	2625	2750
862RSL13004	2250	2625	2800	2800	3000
862RSL13006	2438	2750	3000	3000	3188
1020RDL1310	2625	3125	3375	3375	3625
1020RDL1312	3063	3438	3750	3750	4000
1020RDL1314	3125	3600	4000	4000	4250

[General notes on page 20 may apply to this page.](#)
[See available modifications on page 19.](#)

50 Hertz

4-Pole Three Phase Medium Voltage Generators

1500 RPM
Class H Insulation
40°C Ambient
0.8 Power Factor Lagging
DVR®2400 AVR w/PMG Excitation

DATA MAX™

FEATURES:

- Low Reactance Designs (*Contact factory for other custom reactance value designs)
- Other voltage designs available (Contact factory for details)

3300Y/1905 Volt or 1905 Volts Delta

All 860 frame generators have 4 bus bars, with the capability of differential protection.

Base Model	Ratings @ Designated Rise									
	Continuous						Standby			
	B 80°C R/R		F 105°C R/R		H 125°C R/R		F 130°C R/R		H 150°C R/R	
	kVA	kW	kVA	kW	kVA	kW	kVA	kW	kVA	kW
6Lead,4 Bus Bars, Form Wound Coils and VPI Insulation Systems.										
862FSM15312	1825	1460	2063	1650	2275	1820	2275	1820	2413	1930
862FSM15314	2000	1600	2250	1800	2500	2000	2500	2000	2650	2120
862FSM15316	2250	1800	2500	2000	2750	2200	2750	2200	2913	2330
863FSM15320	2500	2000	2875	2300	3000	2400	3000	2400	3125	2500

6600Y/3811 Volts or 3811 Volts Delta

All 860 frame generators have 4 bus bars, with the capability of differential protection.

Base Model	Ratings @ Designated Rise									
	Continuous						Standby			
	B 80°C R/R		F 105°C R/R		H 125°C R/R		F 130°C R/R		H 150°C R/R	
	kVA	kW	kVA	kW	kVA	kW	kVA	kW	kVA	kW
6Lead,4 Bus Bars, Form Wound Coils and VPI Insulation Systems.										
862FSM15432	1825	1460	2063	1650	2275	1820	2275	1820	2413	1930
862FSM15434	2000	1600	2250	1800	2500	2000	2500	2000	2650	2120
862FSM15436	2250	1800	2500	2000	2750	2200	2750	2200	2913	2330
863FSM15440	2500	2000	2875	2300	3000	2400	3000	2400	3125	2500

- Medium voltage sensing potential transformers (P/Ts) are not included. For three-phase sensing, a three-phase PT is required.
- Price adder may apply
- All 860 and 1000 frame generators on this page have 100 ohm platinum winding RTDs as standard equipment.

[General notes on page 20 may apply to this page.](#)
[See available modifications on page 19.](#)

**4-Pole
Three Phase
High Voltage
Generators**

**50
Hertz**

**1500 RPM
Class F Insulation
40°C Ambient
0.8 Power Factor Lagging
DVR®2400 AVR w/PMG Excitation
6 Leads**

DATA MAX™ Standard Models

FEATURES:

- Low Reactance Designs (*Contact factory for other custom reactance value designs)
- Other voltage designs available (Contact factory for details)

10000Y/5774 Volts or 5774 Volts Delta

Base Model	Ratings @ Designated Rise					
	Continuous				Standby	
	B 80°C R/R		F 105°C R/R		F 130°C R/R	
	kVA	kW	kVA	kW	kVA	kW
862FSH14156	1488	1190	1719	1375	1838	1470
863FSH14158	1700	1360	1956	1565	2075	1660
863FSH14160	1875	1500	2169	1735	2313	1850
863FSH14162	2050	1640	2375	1900	2500	2000
1020FDH1440	1500	1200	1725	1380	1881	1505
1020FDH1442	1775	1420	2038	1630	2200	1760
1020FDH1444	1788	1430	2050	1640	2213	1770
1020FDH1446	1825	1460	2063	1650	2225	1780
1020FDH1448	2063	1650	2375	1900	2575	2060
1030FDH1450	2188	1750	2525	2020	2725	2180
1030FDH1452	2188	1750	2525	2020	2725	2180
1030FDH1454	2363	1890	2775	2220	3025	2420

Consult factory for extended ratings.

10500Y/6062 Volts or 6062 Volts Delta

Base Model	Ratings @ Designated Rise					
	Continuous				Standby	
	B 80°C R/R		F 105°C R/R		F 130°C R/R	
	kVA	kW	kVA	kW	kVA	kW
862FSH14156	1563	1250	1813	1450	1938	1550
863FSH14158	1788	1430	2063	1650	2188	1750
863FSH14160	1975	1580	2288	1830	2500	2000
863FSH14162	2162	1730	2500	2000	2625	2100
1020FDH1440	1563	1250	1781	1425	1925	1540
1020FDH1442	1850	1480	2100	1680	2250	1800
1020FDH1444	1888	1510	2125	1700	2288	1830
1020FDH1446	1900	1520	2150	1720	2325	1860
1020FDH1448	2075	1660	2388	1910	2588	2070
1030FDH1450	2288	1830	2638	2110	2838	2270
1030FDH1452	2288	1830	2638	2110	2838	2270
1030FDH1454	2425	1940	2863	2290	3138	2510

Consult factory for extended ratings

11000Y/6351 Volts or 6351 Volts Delta

Base Model	Ratings @ Designated Rise					
	Continuous				Standby	
	B 80°C R/R		F 105°C R/R		F 130°C R/R	
	kVA	kW	kVA	kW	kVA	kW
862FSH14156	1563	1250	1813	1450	1813	1550
863FSH14158	1788	1430	2063	1650	2188	1750
863FSH14160	1975	1580	2288	1830	2500	2000
863FSH14162	2162	1730	2500	2000	2625	2100
1020FDH1440	1500	1200	1750	1400	1875	1500
1020FDH1442	1775	1420	2063	1650	2188	1750
1020FDH1444	1838	1470	2175	1740	2363	1890
1020FDH1446	1900	1520	2250	1800	2425	1940
1020FDH1448	1975	1580	2375	1900	2588	2070
1030FDH1450	2150	1720	2500	2000	2813	2250
1030FDH1452	2188	1750	2550	2040	2875	2300
1030FDH1454	2500	2000	2913	2330	3200	2560

Consult factory for extended ratings

• High voltage sensing potential transformers (P/Ts) are not included. For three-phase sensing, a three-phase PT is required.

• All 860 and 1000 frame generators on this page have 100 ohm platinum winding RTDs as standard equipment.

• All high voltage generators incorporate form wound coils and VPI insulation systems.

• All 860 and 1000 frame frame generators have 4 bus bars, with the capability of differential protection.

• Consult factory for altitude above 1000 MASL.

General notes on page 20 may apply to this page.
See available modifications on page 19.



220/110 Volts
440/220 Volts
110 Volts Delta

1500 RPM
Class H Insulation
40°C Ambient
SE350E AVR w/Shunt (Non-PMG)
Excitation

MAGNAPLUS® Standard Models

Base Model	Ratings @ Designated Rise									
	0.8 Power Factor Lagging						1.0 Power Factor			
	Continuous				Standby		Continuous		Standby	
	F 105°C R/R		H 125°C R/R		H 150°C R/R		F 105°C R/R	H 125°C R/R	H 150°C R/R	
kVA		kW		kVA		kW		kVA/kW	kVA/kW	kVA/kW
12 Lead Reconnectable with Link Board as Standard										
282PSL1502	6.9	5.5	7.5	6	7.8	6.2	7.5	8	8.5	
282PSL1504	9.4	7.5	10	8	10.6	8.5	10	11	11.5	
282PSL1505	12.8	10.2	13.8	11	14.4	11.5	13	14	15	
283PSL1506	14.4	11.5	16.3	13	16.9	13.5	16	18	19	
283PSL1507	16.3	13	16.9	13.5	17.5	14	19	20	21	
284PSL1508	20	16	22.5	18	25	20	24	26	28	
284PSL1542	22.5	18	25	20	26.3	21	25	27	29	
361PSL1600	25	20	26	21	29	23	28	30	32	
361PSL1601	29	23	31	25	34	27	33	35	38	
361PSL1602	33	26	35	28	39	31	37	40	43	
362PSL1604	44	35	48	38	53	42	46	50	54	
362PSL1606	51	41	56	45	60	48	56	60	65	
363PSL1607	58	46	63	50	66	53	60	65	70	
431PSL6202	90	72	95	76	100	80	90	95	100	
431PSL6204	100	80	110	88	115	92	100	110	115	
431PSL6206	120	96	130	104	135	108	120	130	135	
431PSL6208	125	100	140	112	145	116	125	140	145	
432PSL6210	150	120	165	132	170	136	150	165	170	
432PSL6212	150	120	165	132	170	136	150	165	170	
433PSL6216	190	152	200	160	215	172	190	200	215	
433PSL6220	190	152	200	160	215	172	190	200	215	

[General notes on page 20 may apply to this page.](#)
[See available modifications on pages 19.](#)

**4-Pole
Dedicated
Single Phase
Generators**

**50
Hertz**

220/110 or 110 Volts

**1500 RPM
Class H Insulation
40°C Ambient
SE350EL AVR w/Shunt (Non-PMG) Excitation**

MAGNAPLUS[®] Standard Models

Base Model	Ratings @ Designated Rise								
	0.8 Power Factor Lagging						1.0 Power Factor		
	Continuous				Standby		Continuous		Standby
	F 105°C R/R		H 125°C R/R		H 150°C R/R		F 105°C R/R	H 125°C R/R	H 150°C R/R
	kVA	kW	kVA	kW	kVA	kW	kVA/kW	kVA/kW	kVA/kW
4 Lead with Link Board as Standard									
282PSL1513	6.6	5.3	7.5	5.7	7.5	6	9.5	10	10.5
282PSL1515	9.4	7.5	10	8	10.6	8.5	13	14	15
282PSL1517	15.6	12.5	16.9	13.5	18.1	14.5	22	24	25
361PSL1613	39	31	44	35	46	37	50	54	58
362PSL1615	39	31	44	35	46	37	55	60	65

[General notes on page 20 may apply to this page.](#)
[See available modifications on pages 19.](#)



200Y or 400Y Volts
400Y Volts

1000 RPM
Class H Insulation
40°C Ambient
0.8 Power Factor Lagging
DVR®2400 AVR w/PMG Excitation

MAGNAMAX®

Base model	Ratings @ Designated Rise									
	Continuous						Standby			
	B 80°C R/R		F 105°C R/R		H 125°C R/R		F 130°C R/R		H 150°C R/R	
	kW	kVA	kW	kVA	kW	kVA	kW	kVA	kW	kVA
12 Leads, 200Y or 400Y Volts										
572RSL0120	128	160	144	180	160	200	160	200	170	213
572RSL0122	160	200	185	231	200	250	200	250	210	263
572RSL0124	200	250	230	288	250	313	250	313	260	325
573RSL0126	240	300	275	344	300	375	300	375	315	394
573RSL0128	320	400	365	456	400	500	400	500	420	525
574RSL0130	400	500	460	575	500	625	500	625	525	656
6 Leads, 400Y Volts										
742RSL0132	480	600	550	688	600	750	600	750	630	788
742RSL0134	640	800	735	919	800	1000	800	1000	840	1050
743RSL0136	800	1000	915	1144	1000	1250	1000	1250	1050	1313
744RSL0138	960	1200	1100	1375	1200	1500	1200	1500	1260	1575

Contact your sales representative for lead time and available agency options.

[General notes on page 20 may apply to this page.](#)

[See available modifications on page 19.](#)

Modification Section: Generators

Modification	Description	280	360	430	570	740
Adapters	Two-bearing close-coupled	⊘	⊘	⊘	▲	▲
Drip Cover	IP22	●	●	●	●	●
	IP23	●	●	●	●	●
PMG Excitation	SE350 or SE350EL - see model list for availability	■	■	■	⊘	⊘
	Permanent Magnet Generator & PM500 Regulator - see model list for availability	●	●	●	■	⊘
	Permanent Magnet Generator & DVR®2400 Regulator- see model list for availability	●	●	●	●	■
Space Heaters 240 / 120V	Watts vary by frame size	50W	120W	180W	480W	600W
Stator RTD	MagnaMax, MagnaPower	⊘	⊘	⊘	●	●
Bearing RTD	MagnaMax, MagnaPower	⊘	⊘	⊘	●	●
Current Transformer	Paralleling, Metering, or Differential- proper bus bar selection required	⊘	⊘	⊘	●	●
Sensing Transformer	3 Phase for voltage regulator sensing only, MV & HV generators	⊘	⊘	⊘	▲	▲
Bus Bars	572-744Frame- to be selected in conjunction with current transformers	⊘	⊘	⊘	▲	▲

- standard
- ⊘ not available
- ▲ consult sales rep for additional information
- Optional; upcharge may apply, depending on model

*CSA is a tradename of CSA Group and is not owned by or under the control of Marathon Electric LLC.

General Notes

- A. All base models listed (except 1000 frame MAGNAPOWER® models) are single bearing. Pricing includes flexible drive discs, SAE adapter, standard voltage regulator, and full guarding. Drip covers are Optional. All voltage regulators have underspeed protection, EMI filtering, and are encapsulated for moisture protection.
- B. MAGNAPLUS® and MAGNAMAX® products have Class H insulation. MAGNAPOWER® products have Class H insulation for 4160V and below, and Class F insulation for above 4160V. Rating columns headed B, F, and H indicate that generators operated at the specified ratings will not exceed the temperature rise limitation for the specified class of insulation specified in MG1-32.6. The rating columns do not specify the class of insulation used in the generator's construction.
- C. The frame size for each model is the first 3 or 4 digits of the model number.
- D. All generator ratings listed in this publication are based upon temperature rises measured by the resistance method as defined by MIL-STD-705C and IEEE STD 115, Method 6.4.4. For ratings at rises as measured by embedded temperature detectors, consult factory.
- E. MAGNAPLUS® products are shunt-excited (non-PMG) generators. The automatic voltage regulator derives input power from the generator's output leads.
- F. MAGNAMAX® and MAGNAPOWER® generators incorporate a permanent magnet generator (PMG) as the input power source for the voltage regulator.
- G. MAGNAMAX® and MAGNAPOWER® form wound coil generators include VPI insulation on main stator only.

Technical Data

Mounting Arrangement Cross Reference

Adapter SAE Size	Coupling Size	Available in Frame Sizes				
		MagnaPlus			MagnaMax	
		280	360	430	570	740
5	7.5	X				
4	7.5	X				
4	10	X				
3	10	X	X	X		
3	11.5	X	X	X		
2	10		X	X		
2	11.5		X	X		
1	11.5		X	X		
1	14		*	X	X	
0.5	14			X	X	
0	14			X	X	
0	18				X	X
00	18					X
00	21					X

* Dedicated adaption, cannot be changed.

Dimensions & Weights

in inches and (millimeters)

Standard SAE Dimensions

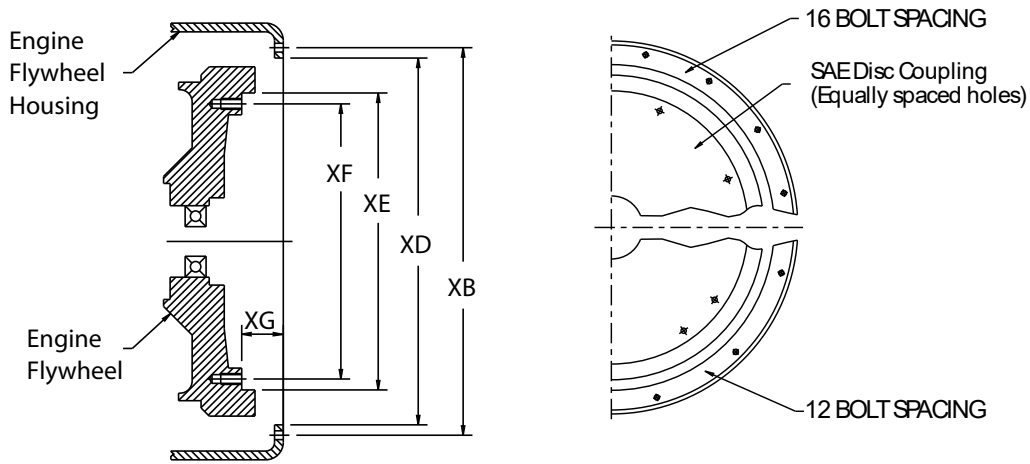

Engine Flywheel Housing Dimensions				
SAE No.	XD	XB	Tapped Holes	
			Qty.	Size
00	31.000 (787)	33.50 (851)	16	1/2-13
0	25.500 (648)	26.75 (679)	16	1/2-13
1/2	23.000 (584)	24.38 (619)	12	1/2-13
1	20.125 (511)	20.88 (530)	12	7/16-14
2	17.625 (448)	18.38 (467)	12	3/8-16
3	16.125 (410)	16.88 (429)	12	3/8-16
4	14.250 (362)	15.00 (381)	12	3/8-16
5	12.375 (314)	13.12 (333)	8	3/8-16
6	10.500 (267)	11.25 (286)	8	3/8-16

Engine Flywheel Dimensions					
Size	XE	XF	XG	Tapped Holes	
				Qty.	Size
SAE 21	26.500 (673)	25.25 (641)	0 (0)	12	5/8-11
SAE 18	22.500 (572)	21.38 (543)	.62 (16)	6	5/8-11
SAE 14	18.375 (467)	17.25 (438)	1.00 (25)	8	1/2-13
SAE 11-1/2	13.875 (352)	13.12 (333)	1.56 (40)	8	3/8-16
SAE 10	12.375 (314)	11.62 (295)	2.12 (54)	8	3/8-16
SAE 8	10.375 (264)	9.62 (244)	2.44 (62)	6	3/8-16
SAE 7-1/2	9.500 (241)	8.75 (222)	1.19 (30)	8	5/16-18
SAE 6-1/2	8.500 (216)	7.88 (200)	1.19 (30)	6	5/16-18

MARINER®
HARSH DUTY®

Mariner & Harsh Duty Net Weight in kilograms

Base Model	Weight
361PSL3120	240
361PSL3121	254
361PSL3122	285
362PSL3124	330
362PSL3126	354
363PSL3127	420

Base Model	Weight
431PSL6252	535
431PSL6254	580
431PSL6256	635
431PSL6258	660
432PSL6260	755
432PSL6262	795
433PSL6266	940
433PSL6270	995

Base Model	Weight
572RSL6325	1205
572RSL6327	1235
572RSL6329	1383
572RSL6331	1411
573RSL6333	1545
573RSL6335	1570
574RSL6337	1851

Dimensions & Weights

in millimeters

ALL DIMENSIONS ARE APPROXIMATE: Contact factory for full dimensional data.

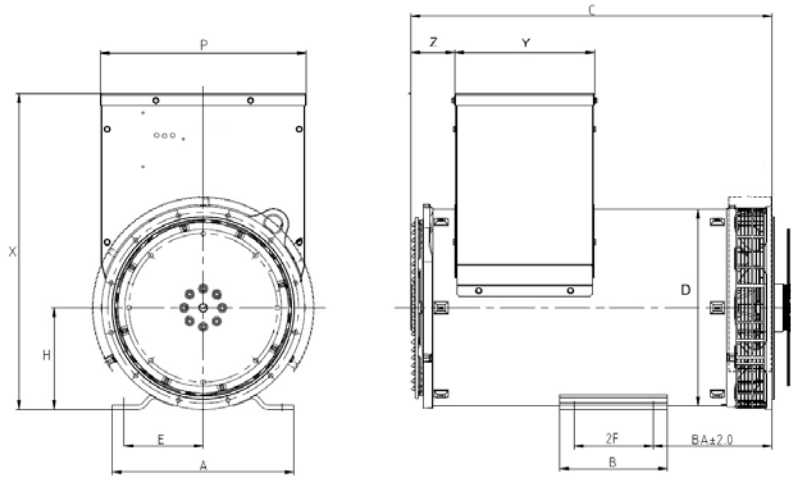

280-430 frame

Frame Size	A	B	BA	C	C with PMG	D	E	2F	H	P	X	Y	Z
282	355.6	178	166.6	466	596	346.7	158.8	127	203	353	475	174	96
283	355.6	178	166.6	529	659	346.7	158.8	127	203	353	475	174	96
284	355.6	178	166.6	580	710	346.7	158.8	127	203	353	475	174	96
361	408	242	177.8	639	699	442	177.8	177.8	228.6	464	710	316	98
362	408	242	177.8	731	791	442	177.8	177.8	228.6	464	710	316	98
363	408	242	266.7	811	871	442	177.8	177.8	228.6	464	710	316	98
364	408	242	266.7	888	948	442	177.8	177.8	228.6	464	710	316	98
431	533.4	381	254	852	977	575	228.5	279.4	330	603	855	380	57
432	533.4	381	254	941	1066	575	228.5	279.4	330	603	855	380	57
433	533.4	381	254	1068	1193	575	228.5	279.4	330	603	855	380	57

Must have minimum clearance of 153mm for air flow in to the generator. Additional clearance may be required for servicing.

MagnaPlus Net Weight in kilograms

Base Model	Weight
282PSL1502	102
282PSL1504	115
282PSL1505	135
283PSL1506	150
283PSL1507	165
284PSL1508	195
284PSL1542	200
282PSL1513	100
282PSL1515	120
282PSL1517	131

Base Model	Weight
361PSL1600	240
361PSL1601	254
361PSL1602	285
361PSL1613	284
362PSL1604	330
362PSL1606	354
362PSL1615	353
363PSL1607	420
364PSL1609	440
431PSL6202	535

Base Model	Weight
431PSL6204	580
431PSL6206	635
431PSL6208	660
432PSL6210	755
432PSL6212	795
433PSL6216	940
433PSL6220	995

DIMENSIONS | TECHNICAL

Dimensions & Weights

in millimeters

ALL DIMENSIONS ARE APPROXIMATE: Contact factory for full dimensional data

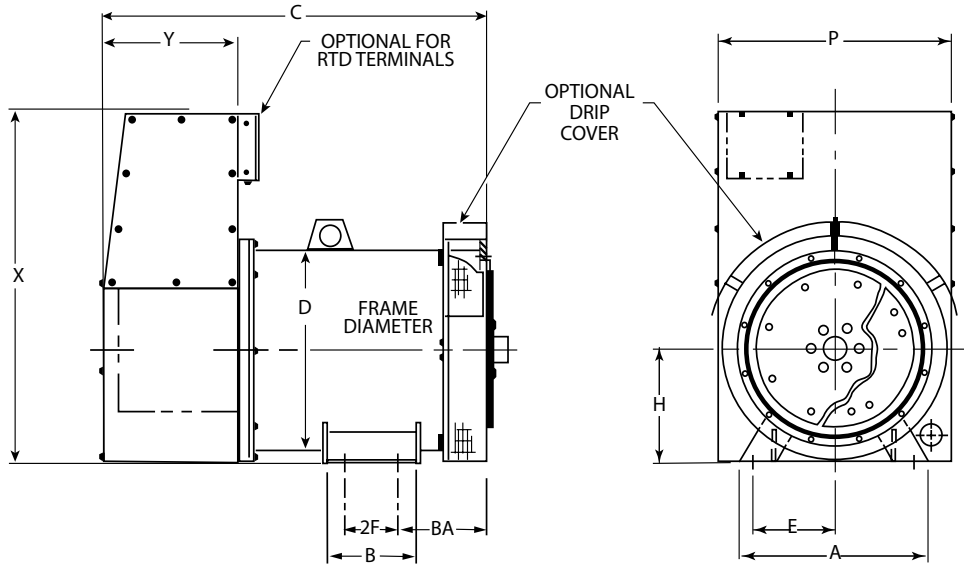

Frame Size	A	B	BA	C	D	E	2F	H	P	X	Y
572	571.5	381	292.1	1306	702	254	279.4	393	780	1078.5	432
573	571.5	610	292.1	1470	702	254	508	393	780	1078.5	432
574	571.5	610	292.1	1648	702	254	508	393	780	1078.5	432
575	571.5	610	292.1	1705	702	254	508	393	780	1078.5	432
742	838	725.8	304.8	1763	870	381	584.2	482	960	1304	539
743	838	1081.6	304.8	2011	870	381	940	482	960	1304	539
744	838	1081.6	304.8	2169	870	381	940	482	960	1304	539
764	838	1081.6	368.8	2233	870	381	940	482	960	1304	539

- Notes:
- Connection boxes shown are furnished as standard product. Consult factory for optional connection boxes.
 - Must have a minimum clearance of 153 mm for air flow into the conduit box. However, additional clearance may be required for servicing.

Dimensions & Weights

ALL DIMENSIONS ARE APPROXIMATE: Contact factory for full dimensional data

Net Weight in kilograms

Model	Weight
572RSL0120	930
572RSL0122	1000
572RSL0124	1135
572RSL6425	1205
572RSL6427	1235
572RSL6429	1383
572RSL6431	1411
573RSL0126	1350
573RSL0128	1550
573RSL6433	1545
573RSL6435	1570
574RSL0130	1880
574RSL6437	1851
574RSL6438	1930
575RSL4044	2265
740RSL4046	2359
742RSL0132	2943
742RSL0134	3374
742RSL4048	2765
742RSL4050	3090
743RSL0136	3950
743RSL4052	3412
744RSL0138	4237
744RSL4054	3782
744RSL4056	4418
744RSL4058	4347
764RSL4063	4507

Dimensions & Weights

in millimeters

ALL DIMENSIONS ARE APPROXIMATE: Contact factory for full dimensional data

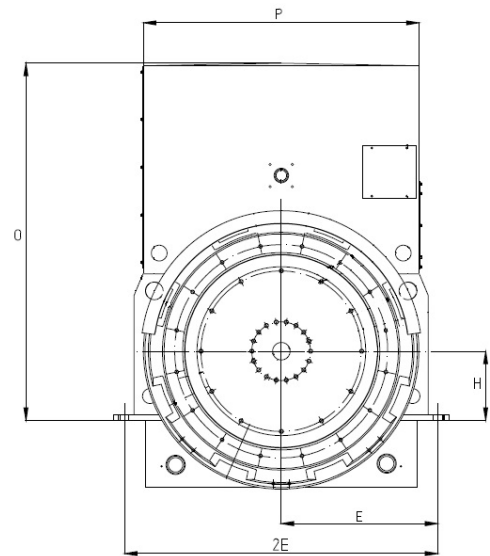
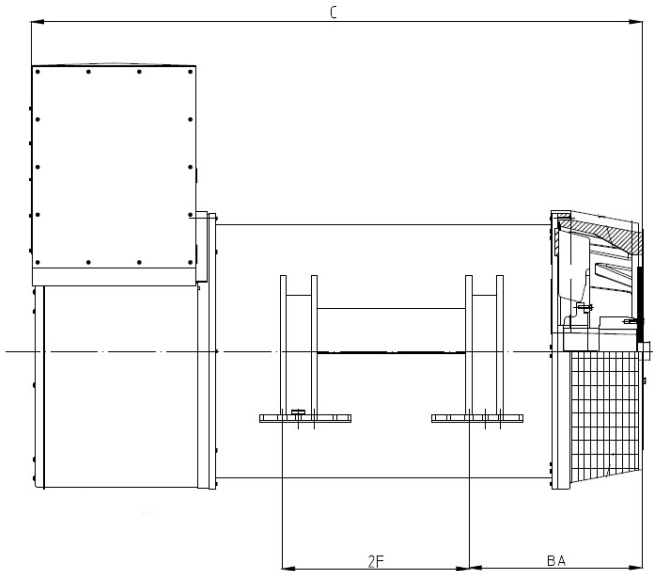

Frame Size	C	BA	2F	E	2E	H	O	P
861	2438.4	690.6	745	625	1250	276	1424.5	1100.6
862	2608.4	690.6	870	625	1250	276	1424.5	1100.6
863	2766.4	690.6	1000	625	1250	276	1424.5	1100.6

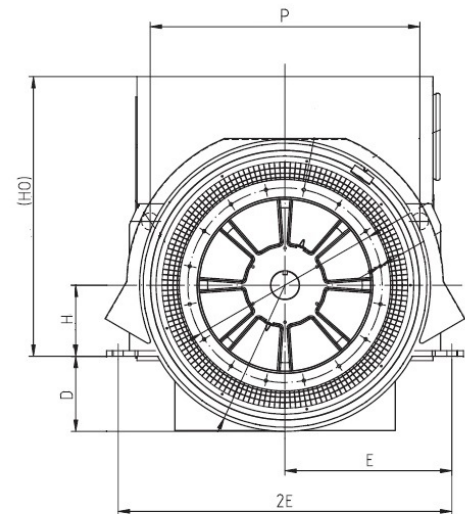
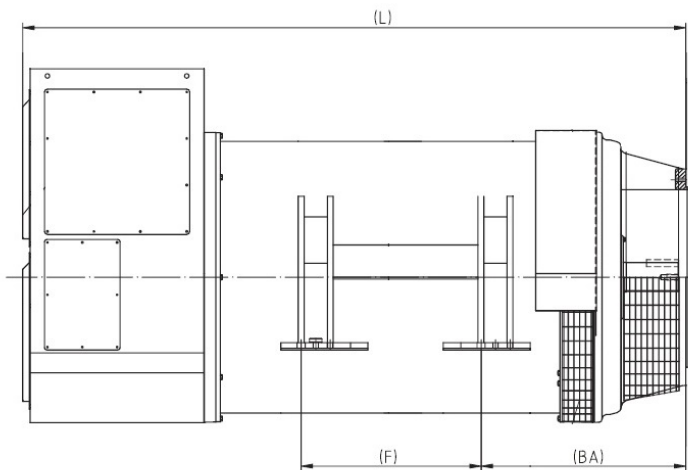

Frame Size	BA	C	D	E	2E	2F	H	O	P
1020	896.1	2902	328	730.25	1460.5	787.4	311	1223	1179.3
1030	896.1	3041	328	730.25	1460.5	787.4	311	1223	1179.3

- Notes:
- Connection boxes shown are furnished as standard product. Consult factory for Optional connection boxes.
 - Must have a minimum clearance of 153 mm for air flow into the conduit box. However, additional clearance may be required for servicing.

Dimensions & Weights

Net Weight in kilograms

ALL DIMENSIONS ARE APPROXIMATE: Contact factory for full dimensional data

Net Weight in kilograms

Model	Weight
861RSL13002	5017
862RSL13004	5543
862RSL13006	6251
862FSH14156	5850
863FSH14158	5975
863FSH14160	6780
863FSH14162	7099
1020RDL1310	8490
1020RDL1312	8770
1020FDH1440	6350
1020FDH1442	6441
1020FDH1444	6566
1020FDH1446	6759
1020FDH1448	7031
1030RDL1314	9290
1030FDH1450	7348
1030FDH1452	8029
1030FDH1454	8165

Technical Data

Environmental and Special Considerations

Once the size of the generator has been determined, it is important to review the environmental and special conditions which may affect the life of the generator. Some of the most common conditions which may require special attention are outlined below.

ALTITUDE / AMBIENT - For applications over 1000 meters elevation or where the temperature of the ventilating air to the generator exceeds 40°C, derating of the generator will be necessary. To determine the derating, use the chart below by moving vertically on the specified altitude to the horizontal line that matches the required ambient temperature, then select the derating required.

Note: When a class of insulation is specified, additional derating of kW available may be necessary. Per MG 1-2011, Part 32.6: For successful operation of generators in ambient temperatures higher than 40°C, the temperature rises... shall be reduced by the number of degrees that the ambient temperature exceeds 40°C.

ABRASIVE DUSTS - When it is possible that airborne abrasive dusts will be introduced to the generator with the ventilating air, additional protection is recommended. Dirt, sand, volcanic ash, gravel, rock dust, etc. are typical of this type of application. Although the generator windings are protected against abrasive environments, severe conditions may warrant protection by means of baffles, housings and filters, or other suitable means. Refer to factory for recommendations.

HIGH HUMIDITY AND TROPICAL CLIMATE - In moist or humid areas such as the Tropics, coastal areas, and all marine service, additional protection is recommended. Although the standard windings are humidity and moisture resistant, space heaters are required for these environments.

OUTDOOR APPLICATION - All generators for outdoor application must be protected from the elements by sheet metal housings with the proper openings for ventilation. This protection should be designed to prevent the direct contact of wind driven rain, snow, or dust with the generator. Space heaters are recommended depending on location and type of service. Refer to factory for recommendations on enclosure requirements.

NON-LINEAR LOADING - Solid state electronic control devices which utilize thyristors or SCR firing circuits (such as variable frequency induction motor controls, precision motor speed controls, no-break powered battery chargers, etc.) can introduce high frequency harmonics which adversely affect the normal waveform of the generator. This creates additional heat in the generator stator and rotor and can cause overheating. These devices can and do present problems to non-utility power generating equipment or any limited power bus system. The problems which can occur are not limited to the generator itself, but can affect the solid state control device, the equipment it controls, other associated loads, monitoring devices or a number of combinations over the entire system.

It is important that the control manufacturer, the generator manufacturer, and the systems engineer work together to insure the proper selection of all components. Please refer to factory for application assistance.

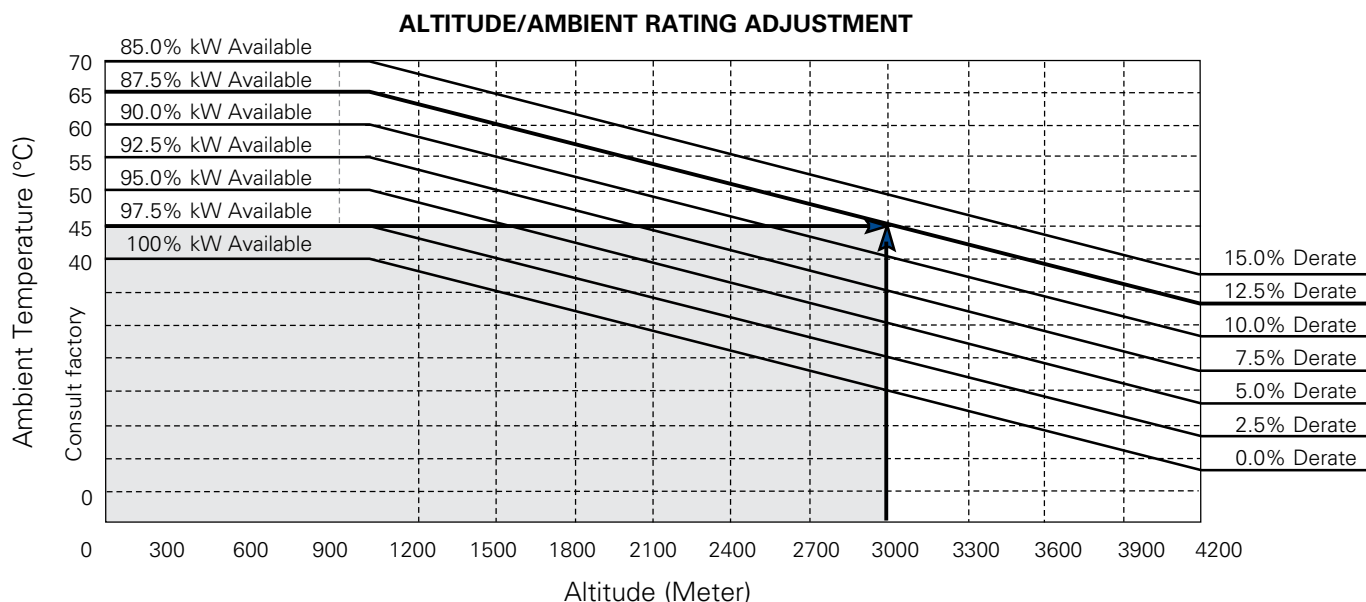

Example:

Elevation: 3000 Meter
 Ambient: 45°C
 Required Derate: 12.5%
 Catalog Rating x .875

Example:

B class of insulation is specified in a 45°C ambient.
 Maximum allowable temperature rise is reduced from 80°C to 75°C.

* is a trademark or trade name of National Electrical Manufacturers Association and is not owned by or under the control of Marathon Electric LLC

Technical Data

Connection Diagrams

SERIES

HIGH WYE

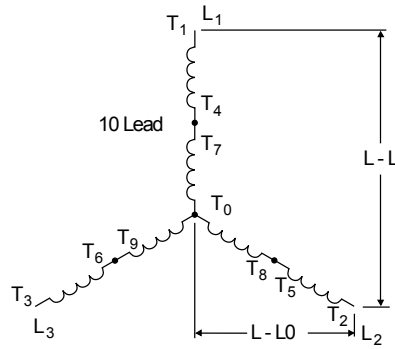
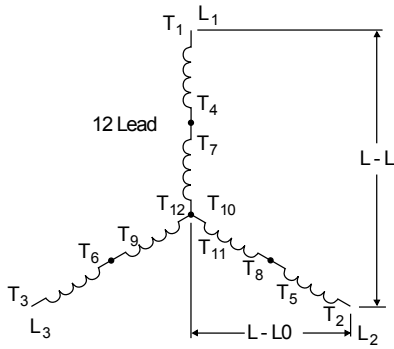

Voltage		
HZ	L-L	L-L0
60	380	219
	416	240
	440	254
	460	266
	480	277
	600	346
50	380	219
	400	231
	415	240
	440	254

PARALLEL

LOW WYE

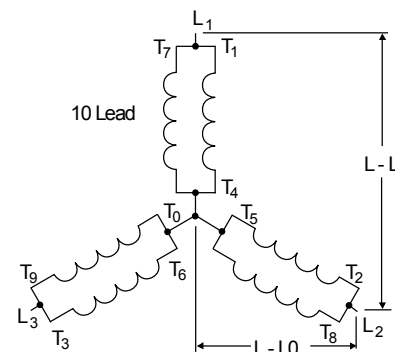
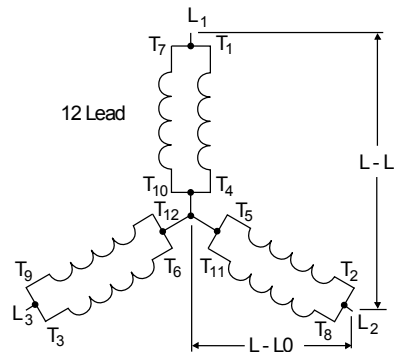

Voltage		
HZ	L-L	L-L0
60	190	110
	208	120
	220	127
	230	133
	240	139
	240	139
50	190	110
	200	115
	208	120
	220	127

WYE

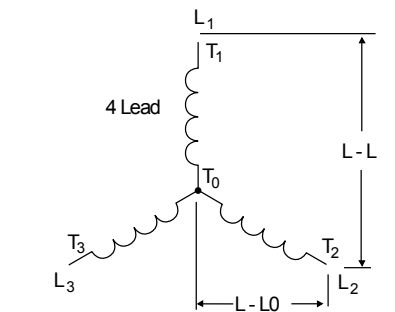
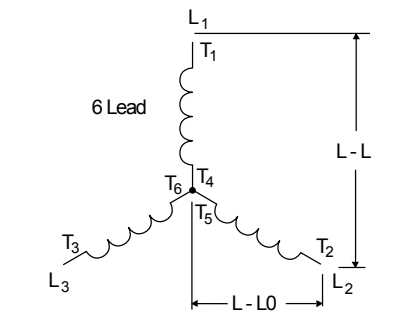

Voltage		
HZ	L-L	L-L0
60	380	219
	480	277
	600	346
	2400	1386
	3300	1905
	4160	2402
	6600	3811
	13800	7967
50	380	219
	400	231
	415	240
	3300	1905
	6600	3811
11000	6351	

SERIES

HIGH DELTA

Voltage		
HZ	L-L	L-L0
60*	240	120
50	200	100
	220	110
	240	120

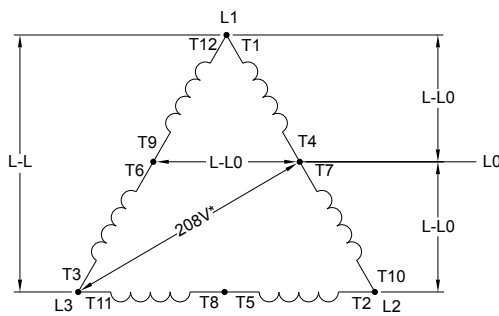

PARALLEL

LOW DELTA

Voltage	
HZ	L-L
60	110
	120
50	100
	110

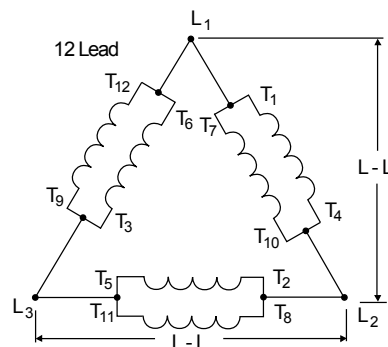

Technical Data

Connection Diagrams

DELTA

Voltage	
HZ	L-L
60	2402 7967
50	1905 6351

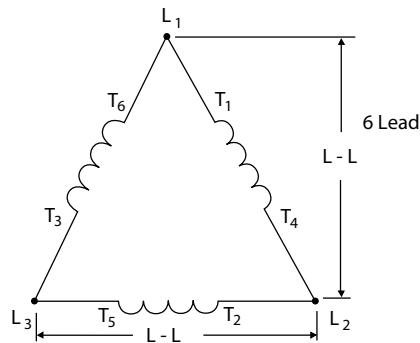

DOUBLE DELTA

Single Phase Connection ①

Voltage		
HZ	L-L	L-L0
60	200 220 240	100 110 120
50	220	110

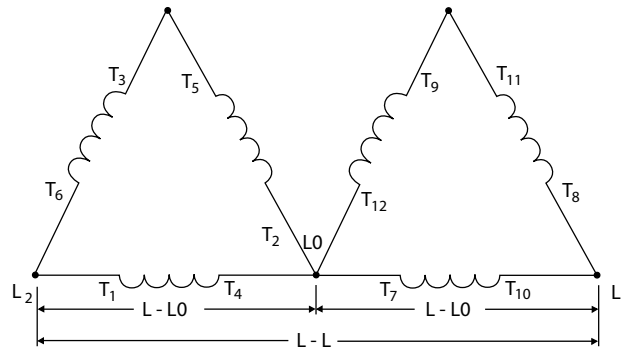

PARALLEL

LOW ZIGZAG

Single Phase Connection ①

Voltage		
HZ	L-L	L-L0
60	200 220 240	100 110 120
50	220	110

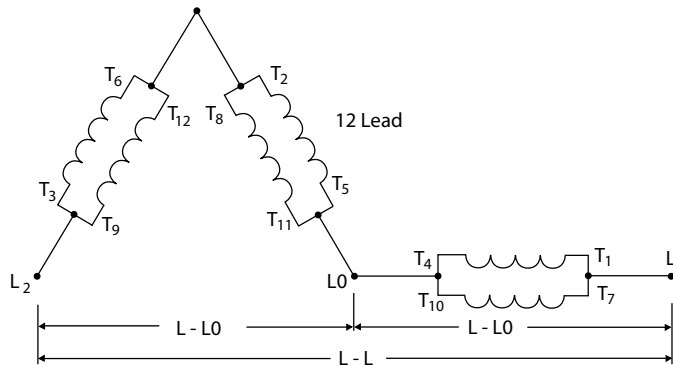

SERIES

HIGH ZIGZAG

Single Phase Connection ①

Voltage		
HZ	L-L	L-L0
60	480	240
50	440	220

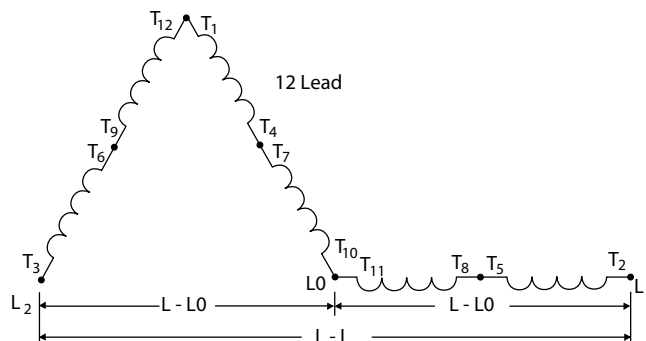

① Single phase kW/kVA ratings are approximately equal to 50% of the generator's three-phase ratings.

Technical Data

Automatic Voltage Regulator Features

Feature	STANDARD MODELS				SPECIAL (OPTIONAL) MODELS
	SE350E	SE350EL	DVR®2400	PM500	DVR®2500
Analog Input	No	No	Yes	Yes	Yes
Min. Exciter Field Resistance Ohms	15.0	15.0	18.0	15.0	18.0
Voltage Regulation No Load to Full Load	1.0%	1.0%	0.25%	0.25%	0.25%
Underspeed Protection	Yes	Yes	Yes	Yes	Yes
Overexcitation Protection	Yes	Yes	Yes	Yes	Yes
EMI / RFI Filtering ①	Yes	Yes	Yes	Yes	Yes
Unit Mounted Voltage Adjust	Std.	Std.	Std.	Std.	Std.
Overvoltage Protection	No	No	Std.	Std.	Std.
Encapsulated	Yes	Yes	Yes	Yes	Yes
Paralleling ③	Opt④	Opt④	Std.	Std.	Std.
Line Drop Compensation	No	No	No	No	No
VAR/PF Controller	No	No	Yes	No	Yes
Input Power - VAC	240	120 or 240②	PMG	PMG	PMG
Cont. Output - ADC	3.5	3.5	4.0	5.0	4.0
Cont. Output - VDC	63	63	100	85	100
Sensing Input - VAC	190-240	85-120 190-240②	100-600	175-280 330-515 420-660	100-600
Sensed Voltage	Average	Average	RMS	RMS	RMS
Sensing Frequency (Hz)	50/60	50/60	50/60	50/60	50/60
Generator Current Limiting Protection	No	No	No	No	No
AVR Condition LEDs	No	No	Yes	No	Yes
3 Phase Sensing	No	No	Yes	Yes	Yes
1 Phase Sensing	Yes	Yes	Yes	Yes	Yes
Loss of Sensing Protection	Yes ⑥	Yes ⑥	Yes	No	Yes
300% Short Circuit Protection	No	No	Yes	Yes	Yes

① With regulator mounted in generator conduit box.

② Depends on switch position.

③ Requires the addition of a paralleling current transformer.

④ Requires the addition of a paralleling module along with a paralleling current transformer.

⑤ Requires the addition of VAR/PF Module.

⑥ Protection is inherent. Sensing and power input share the same two leads.

A loss of sensing (open in the sensing circuit) results in an open in the input power circuit, and the regulator will shut down.

General Formulas

Generator Formulas ①

Desired Data	Single Phase	Three Phase
Kilo Volt Amperes (kVA)	$\frac{\text{Volts} \times \text{Amps}}{1000}$ or $\frac{\text{kW}}{\text{P.F.}}$	$\frac{\sqrt{3} \times \text{Volts} \times \text{Amps}}{1000}$ or $\frac{\text{kW}}{\text{P.F.}}$
Kilowatts (kW)	$\frac{\text{Volts} \times \text{Amps} \times \text{P.F.}}{1000}$ or $\text{kVA} \times \text{P.F.}$	$\frac{\sqrt{3} \times \text{Volts} \times \text{Amps} \times \text{P.F.}}{1000}$ or $\text{kVA} \times \text{P.F.}$
Power Factor (P.F.)	$\frac{\text{kW}}{\text{kVA}}$	$\frac{\text{kW}}{\text{kVA}}$
Amperes When kW is Known	$\frac{\text{kW} \times 1000}{\text{Volts} \times \text{P.F.}}$	$\frac{\text{kW} \times 1000}{\sqrt{3} \times \text{Volts} \times \text{P.F.}}$
Amperes When kVA is Known	$\frac{\text{kVA} \times 1000}{\text{Volts}}$	$\frac{\text{kVA} \times 1000}{\sqrt{3} \times \text{Volts}}$
Minimum HP Required for Prime Mover	$\frac{\text{kW}}{\text{Alternator Efficiency} \times 0.746}$	
Frequency (Hz)	$\frac{\text{Number of Poles} \times \text{RPM}}{120}$	
Revolutions Per Minute (RPM)	$\frac{\text{Hz} \times 120}{\text{Number of Poles}}$	
Number of Poles	$\frac{\text{Hz} \times 120}{\text{RPM}}$	

① P.F. = Power Factor

IMPORTANT INFORMATION

Please Read Carefully

This catalog is not intended to provide operational instructions. Appropriate Marathon® generator instructions provided with the generator and precautions attached to the generator should be read carefully prior to installation, operations and/or maintenance of the equipment. Injury to personnel or generator failure may be caused by improper installation, maintenance or operation.

The following WARNING! and CAUTION! information is supplied for your protection and to provide you with many years of trouble free and safe operation of your Marathon generator.

"WARNING" indicates a hazardous situation that, if not avoided, could result in death or serious injury and "CAUTION" indicates a hazardous situation that, if not avoided, could result in minor or moderate injury.

⚠ WARNING

- Buyer shall be solely responsible for determining the adequacy of the product for any and all uses to which Buyer shall apply the product. The application by Buyer shall not be subject to any implied warranty of fitness for a particular purpose.
- For safety, Buyer or User should provide protective guards over all shaft extensions and any moving apparatus mounted thereon. The User is responsible for checking all applicable safety codes in his area and providing suitable guards. Failure to do so may result in bodily injury and/or damage to equipment.
- Hot oil can cause severe burns. Use extreme care when removing lubrication plugs.
- Disconnect power and lock out drive equipment before working on a generator.
- Always keep hands and clothing away from moving parts.
- The lifting eyes on the generator are not to be used to lift the entire generator set. Only the generator may be safely lifted by the lifting eyes. Do not use the conduit box for lifting or support of the generator.
- Install and ground the generator per local and national codes.
- Discharge all capacitors before servicing the generator.
- Misapplication of a generator in a hazardous environment can cause fire or an explosion and result in serious injury.

⚠ CAUTION

- Never attempt to measure the temperature rise of a generator by touch. Temperature rise must be measured by thermometer, resistance, imbedded detector or thermocouple.
- Operation of a generator at higher than its nameplate ratings may result in fire, damage to equipment or serious injury to personnel.
- Do not apply any force to the generator fan when rotating the generator rotor.
- Mounting bolts should be routinely checked to ensure that the unit is firmly anchored for proper operation.
- Consult qualified personnel with questions. All electrical repairs must be performed by trained and qualified personnel only.
- Generators should not be operated faster than their rated speed.
- For inverter applications, follow the inverter manufacturer's installation guidelines.
- Make sure the generator is properly secured and aligned before operation.

- When installing the generator, insure that loose parts or tools do not fall inside the generator.
- When connecting the generator, be sure to follow the correct wiring diagram for the desired voltage. Ensure that the voltage regulator is connected per the wiring diagram.

Resale of Goods

In the event of the resale of any of the goods, in whatever form, Resellers/Buyers will include the following language in a conspicuous place and in a conspicuous manner in a written agreement covering such sale:

The manufacturer makes no warranty or representations, express or implied, by operation of law or otherwise, as to the merchantability or fitness for a particular purpose of the goods sold hereunder. Buyer acknowledges that it alone has determined that the goods purchased hereunder will suitably meet the requirements of their intended use. In no event will the manufacturer be liable for consequential, incidental or other damages. Even if the repair or replacement remedy shall be deemed to have failed of its essential purpose under Section 2-719 of the Uniform Commercial Code, the manufacturer shall have no liability to Buyer for consequential damages.

Resellers/Buyers agree to also include this entire document including the cautions and warnings above in a conspicuous place and in a conspicuous manner in writing to instruct users on the safe usage of the product.

This information should be read together with all other printed information supplied by Marathon Electric.

For more information contact:

Marathon Electric LLC

100 E. Randolph St., Wausau, WI 54401

Phone: 715-675-3359



Marathon Electric LLC

100 East Randolph Street

Wausau, WI 54402-8003

Phone: 715-675-3359

Fax: 715-675-8026

MarathonElectric.com

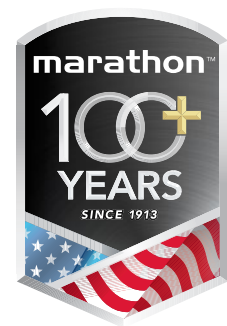

The proper selection and application of products and components, including assuring that the product is safe for its intended use, are the responsibility of the customer.

To view our Standard Terms and Conditions of Sale, please visit <https://www.marathonelectric.com> (which may redirect to other website locations based on product family).

The following trademarks or tradenames are owned by or under the control of a thirdparty and are not owned by Marathon Electric LLC: ATEX is a trademark of European Union; ABS is a trademark or tradename of American Bureau of Shipping; Bureau Veritas is a trademark or trade name of Bureau Veritas; CE is a trademark or tradename of European Unions; CSA is a tradename of CSA Group; Lloyd's Register is a tradename of Lloyd's Register Group Limited; is a trademark or trade name of National Electrical

"Marathon Generators" is not indicative of legal entity.

Marathon, DataMax, DVR, Lima, MagnaMax, MagnaPlus, MagnaPower, MagnaSelect and Mariner are trademarks of Weg SA, or one of its affiliated companies.

©2017, 2022, 2023, 2024 Marathon Electric LLC

MG-CT25083E-R1