

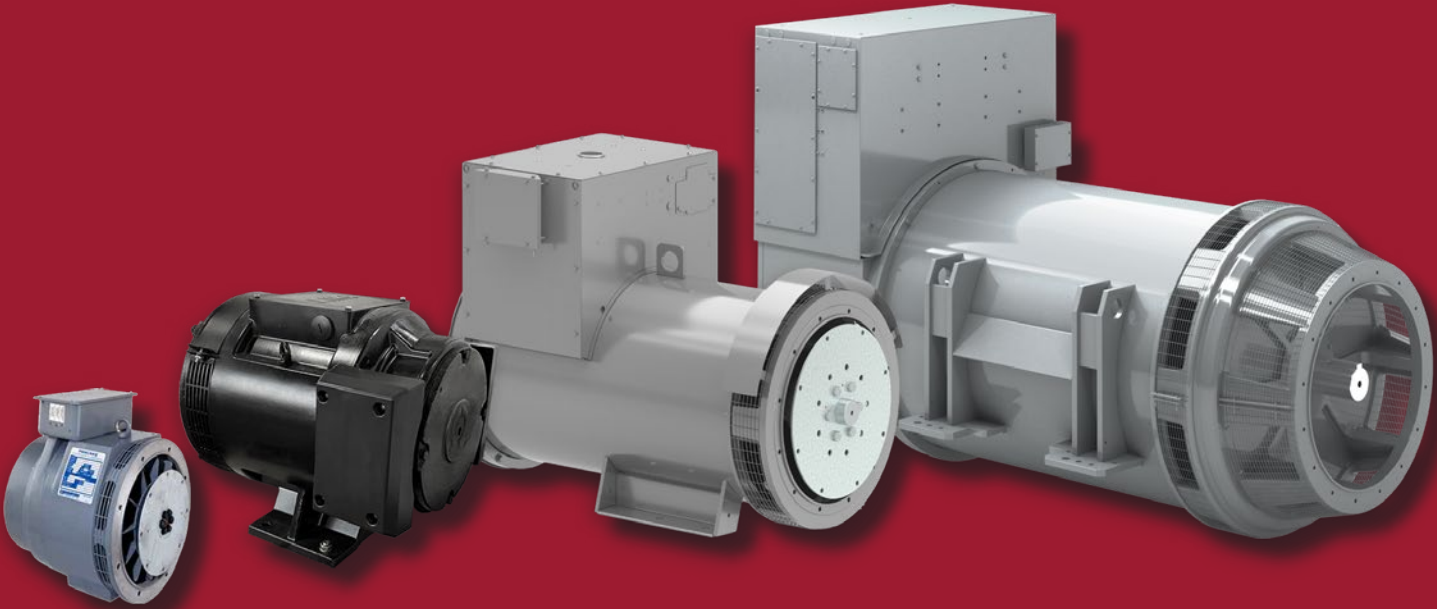

RATINGS & SPECIFICATIONS GUIDE
60 HERTZ AND SPECIALTY GENERATORS
JAN 2025 | CATALOG | NORTH AMERICA, LATIN AMERICA



marathon®

The Marathon® Generator is a top performer in every respect: offering powerful performance, reliable power generation, and easy installation for prime power and emergency standby applications from 5 kW to 4000 kW.

The Marathon Generator brand provides an emphasis on custom and quality-manufactured solutions that provide reliability to customers. Marathon Generator's products are backed by an experienced customer service and technical support staff that are ready and available to support customer needs. Generators are manufactured and inventoried worldwide to meet the needs of our global customer base.

Marathon Generators ... for the long run

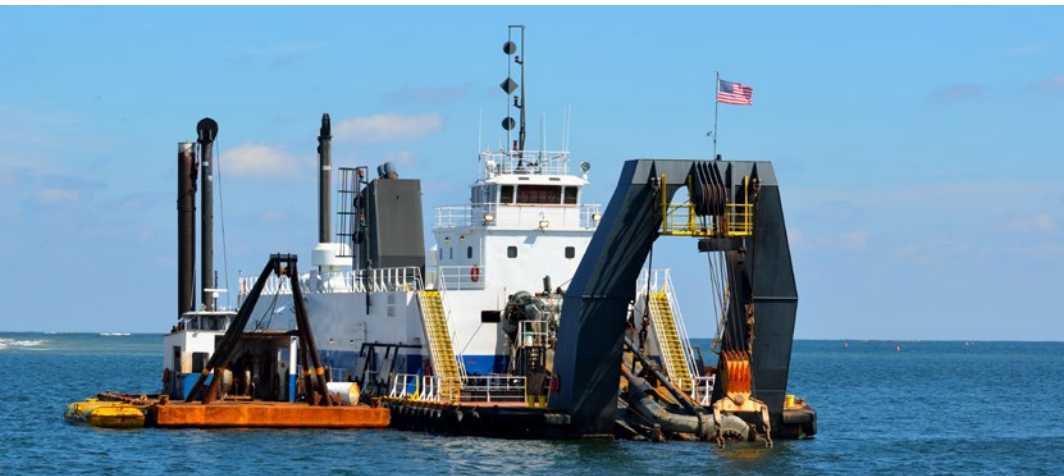

MARINE & HARSH DUTY

These rugged machines are built to withstand the most punishing environments – from hot, arid, dusty mining operations to humid, salt-laden sea air. With reinforced windings, fully encapsulated exciter stators and heavy-duty rectifier assemblies, Marathon's Mariner and Harsh Duty family of alternators deliver low-maintenance reliability.



DATA CENTERS

When mission critical loads are on the line data centers around the world have grown to rely on Marathon® generators as the most trusted, most reliable option when it comes to efficient operation, long life, proven transient performance and guaranteed uptime.

CUSTOM DESIGNS

Highly engineered products designed specifically to your needs.

www.marathonelectric.com

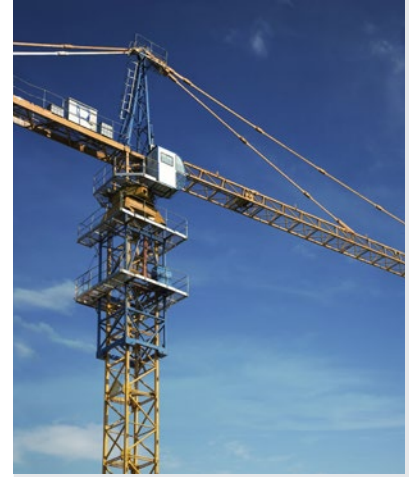

CONSTRUCTION

Our light weight, compact design make our Pancake generators a powerful, economical power source for mobile lighting on construction jobsites.

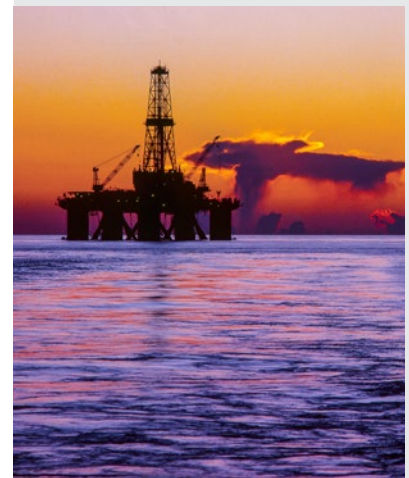

IRRIGATION

Marathon offers generator packages specifically engineered for irrigation applications.

TABLE OF CONTENTS

RATINGS

LOW VOLTAGE - MAGNAPLUS®, MAGNAMAX®, MAGNAPOWER® GENERATORS

Three-phase, 240 Volts - 480 Volts	4-15
Three-phase, dedicated voltage designs - 380/400 Volts, 600 Volts	16-17
Single-phase, 120 Volts - 240 Volts	18-19
Pancake - automatic voltage regulated generators	19

MEDIUM VOLTAGE - MAGNAMAX®, MAGNAPOWER® GENERATORS

2400 Volts - 4160 Volts	20-21
6300 Volts - 6900 Volts	22-24

HIGH VOLTAGE - MAGNAPOWER® GENERATORS

12470 Volts - 13800 Volts	25
---	----

SPECIALTY GENERATORS

Mariner® heavy duty generators	2
Harsh Duty® industrial generators	3
DATAMAX™ data center generators	26
MAGNASELECT® selector switch generators	27
Marine Agency certified generators and requirements	28-29
Mariner®-DEP/SS generators	29
Hazardous Duty - ATEX Zone 2 certified generators	30
Irrigator Duty™	31
LIMA® MAC irrigator	31
6 pole, 1200 rpm generators	32
Drill Rig Duty generators	33
Crane Duty generators	33
Rail Duty generators	34
Responder Duty™ generators	35
Pancake - capacitor regulated generator (light towers)	35
UL Listed, 60 hertz, 4 pole, UL2200 generator ratings	36-37

MODIFICATIONS

Generators, voltage regulators, accessories	38-41
---	-------

TECHNICAL INFORMATION

Standard SAE dimensions & mounting arrangements	42-43
Dimensions, drawings, and weights	44-50
Environmental and special application considerations	51
Connection diagrams	52-53
Automatic voltage regulator features	54
Formulas	55
Agency information	56
Warnings and Cautions	57
Resale of Goods and Freight Policy	58

SALES CONTACTS

Territory Map	61
---	----

* UL is a trademark or trade name of Underwriters Laboratories and is not owned by or under the control of Marathon Electric LLC.

60 Hertz

4-Pole Three Phase Generators

1800 RPM
NEMA®* Class H Insulation
0.8 Power Factor Lagging

MARINER®

FEATURES:

- Reinforced windings with multiple dip & bake cycles on main stator to handle high moisture salt-laden marine applications.
- Fully encapsulated exciter stator for maximum environmental protection.
- Heavy duty rectifier assembly designed to handle extreme voltage transient surges and over-current situations.
- **Regulators:** 280 through 430 frame sizes include **SE350E**; 570 frames include **DVR®2400** with PMG standard.

Base model	kW Ratings @ 50°C Ambient, Cont.			kW Ratings @ 40°C Ambient, Cont.		
	208Y - 240D 95°C R/R	450Y 95°C R/R	480Y 95°C R/R	208Y - 240D 80°C R/R	450Y 80°C R/R	480Y 80°C R/R
12 Lead Reconnectable with Link Board as Standard						
282PSL28043	17.5	17.5	17.5	17	17	17
283PSL28045	25	25	26	24	24	25
284PSL28047	33	33	33	32	32	32
285PSL28048	37	38	40	36	37	38
361PSL3120	37	40	41	35	37	40
361PSL3121	46	48	50	45	48	49
361PSL3122	55	58	60	53	55	58
362PSL3124	67	70	77	65	68	75
362PSL3126	82	83	83	80	80	80
363PSL3127	105	110	115	100	105	110
431PSL6252	133	135	135	125	125	125
431PSL6254	156	160	160	142	143	143
431PSL6256	183	190	186	170	170	165
431PSL6258	195	198	200	176	180	180
432PSL6260	245	245	245	220	220	220
432PSL6262	245	255	260	225	227	230
433PSL6266	325	325	321	290	285	280
433PSL6270	345	355	352	315	315	310
12 Lead Reconnectable with Bus Bars as Standard						
572RSL6325	400	430	430	385	400	380
572RSL6327	415	440	475	400	417	440
572RSL6329	470	505	505	450	475	445
572RSL6331	470	500	515	460	487	485
573RSL6333	610	645	645	570	595	570
573RSL6335	625	652	670	590	617	585
574RSL6337	655	690	700	630	667	670

[General notes on page 42](#) may apply to this page.
[See available modifications](#) on pages 38-41.

*NEMA is a trademark or trade name of National Electrical Manufacturers Association and is not owned by or under the control of Marathon Electric LLC.

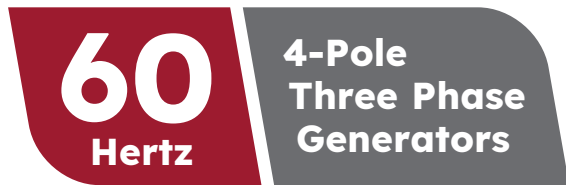

240Y or 480Y Volts

**1800 RPM
NEMA®* Class H Insulation
0.8 Power Factor Lagging
40°C Ambient**

HARSH DUTY®

FEATURES:

- Reinforced windings with multiple dip & bake cycles on main stator to handle dust-laden and/or harsh industrial applications.
- Fully encapsulated exciter stator for maximum environmental protection.
- Heavy duty rectifier assembly designed to handle extreme voltage transient surges and over-current situations.
- **Regulators:** 280 through 430 frame sizes include **SE350E**; 570 frames include **DVR®2400** with PMG standard.

Base model	kW Ratings @ Designated NEMA Rise				
	Continuous			Standby	
	NEMA B 80°C R/R	NEMA F 105°C R/R	NEMA H 125°C R/R	NEMA F 130°C R/R	NEMA H 150°C R/R
12 Lead Reconnectable with Link Board as Standard					
282PSL28043	17	20	21	21	22
283PSL28045	25	30	33	33	35
284PSL28047	32	36	40	40	45
285PSL28048	38	43	45	45	50
361PSL3120	40	45	48	48	50
361PSL3121	49	55	60	60	65
361PSL3122	58	65	70	70	76
362PSL3124	75	84	90	90	95
362PSL3126	80	96	105	105	113
363PSL3127	110	125	135	135	150
431PSL6252	125	142	151	155	160
431PSL6254	143	170	180	181	190
431PSL6256	165	200	211	215	225
431PSL6258	180	211	226	230	240
432PSL6260	220	260	275	280	291
432PSL6262	230	275	300	300	310
433PSL6266	280	342	375	380	400
433PSL6270	310	375	403	415	430
12 Lead Reconnectable with Bus Bars as Standard					
572RSL6325	380	450	475	475	505
572RSL6327	440	500	515	515	560
572RSL6329	445	535	560	560	610
572RSL6331	485	575	600	600	645
573RSL6333	570	680	700	700	765
573RSL6335	585	710	750	750	810
574RSL6337	670	800	825	825	900

[General notes on page 42](#) may apply to this page.
[See available modifications](#) on pages 38–41.

60
Hertz

**4-Pole
Three Phase
Generators**

240Y or 480Y Volts

1800 RPM
NEMA®* Class H Insulation
40°C Ambient
0.8 Power Factor Lagging
Shunt (Non-PMG) Excitation
SE350E AVR

MAGNAPLUS® Standard Models

Base Model	kW Rating @ Designated NEMA Rise				
	Continuous			Standby	
	NEMA B 80°C R/R	NEMA F 105°C R/R	NEMA H 125°C R/R	NEMA F 130°C R/R	NEMA H 150°C R/R
12 Lead Reconnectable with Link Board as Standard					
282PSL1704	12.5	15	16.5	16.5	17.5
282PSL1705	17	20	21	21	22
283PSL1706	22	25	27	27	29
283PSL1707	25	30	33	33	35
284PSL1708	30	32	35	35	40
284PSL1742	32	36	40	40	45
285PSL1700	38	43	45	45	50
286PSL1701	44	52	58	58	62
361PSL1600	40	45	48	48	50
361PSL1601	49	55	60	60	65
361PSL1602	58	65	70	70	76
362PSL1604	75	84	90	90	95
362PSL1606	80	96	105	105	113
363PSL1607	110	125	135	135	150
364PSL1608	125	145	155	155	160
364PSL1609	135	160	180	180	185
431PSL6202	125	142	151	155	160
431PSL6204	143	170	180	181	190
431PSL6206	165	200	211	215	225
431PSL6208	180	211	226	230	240
432PSL6210	220	260	275	280	291
432PSL6212	230	275	300	300	310
433PSL6216	280	342	375	380	400
433PSL6220	310	375	403	415	430

[General notes on page 42](#) may apply to this page.
[See available modifications](#) on pages 38–41.

RATINGS

*NEMA is a trademark or trade name of National Electrical Manufacturers Association and is not owned by or under the control of Marathon Electric LLC .

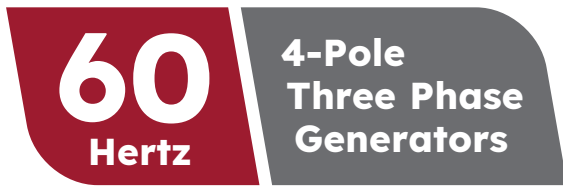

**240Y or 480Y Volts
480Y Volts**

**1800 RPM
NEMA® Class H Insulation
40°C Ambient
0.8 Power Factor Lagging
Includes PMG Excitation**

Regulator: Includes DVR®2400, except 572-574 frame RSL models which include PM500.

MAGNAMAX® Standard Models

Base Model	kW Rating @ Designated NEMA Rise				
	Continuous			Standby	
	NEMA B 80°C R/R	NEMA F 105°C R/R	NEMA H 125°C R/R	NEMA F 130°C R/R	NEMA H 150°C R/R
Random Wound Coil Designs, 12 Lead Reconnectable with Bus Bars Standard, 240Y/480Y					
572RSL6425	380	450	475	475	505
572RSL6427	440	500	515	515	560
572RSL6429	445	535	560	560	610
572RSL6431	485	575	600	600	645
573RSL6433	570	680	700	700	765
573RSL6435	585	710	750	750	810
574RSL6437	670	800	825	825	900
Random Wound Coil Designs, 4 Bars, 480Y Only					
574RSL6438	720	860	915	920	970
575RSL4044	800	975	1050	1060	1130
740RSL4046	950	1120	1200	1220	1250
741RSL4044	865	1030	1080	1100	1100
742RSL4048	1000	1200	1260	1300	1300
742RSL4050	1220	1430	1500	1500	1520
743RSL4052	1310	1600	1700	1750	1750
744RSL4054	1500	1850	1960	2000	2000
744RSL4056	1700	2010	2160	2210	2260
744RSL4057	1760	2100	2270	2320	2370
764RSL4063	2000	2250	2400	2500	2650
Form Wound Coil Designs, 4 Bars, 480Y Only					
573FSL4402	450	525	575	575	600
574FSL4404	570	680	750	750	775
742FSL4408	800	1000	1100	1125	1175
743FSL4410	900	1100	1200	1225	1275
743FSL4412	1025	1250	1325	1350	1375
744FSL4060	1200	1430	1500	1500	1500
744FSL4062	1500	1800	1900	1900	1900
744FSL4414	1630	2000	2110	2110	2110

MAGNAPOWER® Standard Models

All 860 & 1000 frame generators have 4 bus bars, with the capability of differential protection.

Base Model	kW Rating @ Designated NEMA Rise				
	Continuous			Standby	
	NEMA B 80°C R/R	NEMA F 105°C R/R	NEMA H 125°C R/R	NEMA F 130°C R/R	NEMA H 150°C R/R
Random Wound Coil Designs, 6 Lead, 480Y Only					
862RSL86006	2300	2685	2880	2880	3110
1020RDL1109	2550	3050	3250	3250	3400
1020RDL1111	2800	3250	3400	3500	3600
Form Wound Coil Designs, 6 Lead, 480Y Only					
1020FDL1100	1880	2190	2290	2340	2340
1020FDL1102	2000	2250	2500	2500	2500
1020FDL1104	2160	2510	2620	2680	2730
1020FDL1106	2250	2710	2800	2800	2800
863FSL86056	2400	2730	3000	3000	3100
1020FDL1108	2340	2800	2900	3000	3000
1030FDL1110	2530	3080	3260	3350	3350

General notes on page 42 may apply to this page.
See available modifications on pages 38.

60 Hertz **4-Pole Three Phase Generators**

**208Y or 416Y Volts
240 or 120 Volts Delta**

**1800 RPM
NEMA®* Class H Insulation
40°C Ambient
0.8 Power Factor Lagging
Shunt (Non-PMG) Excitation
SE350E AVR**

MAGNAPLUS® Standard Models

Base Model	kW Rating @ Designated NEMA Rise				
	Continuous			Standby	
	NEMA B 80°C R/R	NEMA F 105°C R/R	NEMA H 125°C R/R	NEMA F 130°C R/R	NEMA H 150°C R/R
12 Lead Reconnectable with Link Board as Standard					
282PSL1704	12.5	15	16	16	17.5
282PSL1705	17	20	21	21	22
283PSL1706	21	23	25	25	28
283PSL1707	24	28	30	30	33
284PSL1708	30	32	35	35	40
284PSL1742	32	36	40	40	42
285PSL1700	36	40	45	45	47
286PSL1701	42	50	55	55	58
361PSL1600	35	40	42	42	45
361PSL1601	45	50	55	55	58
361PSL1602	53	60	65	65	68
362PSL1604	65	72	80	80	85
362PSL1606	80	90	100	100	105
363PSL1607	100	110	125	125	135
364PSL1608	125	140	155	155	160
364PSL1609	135	155	175	175	180
431PSL6202	125	140	147	151	155
431PSL6204	142	165	175	176	182
431PSL6206	170	191	202	210	217
431PSL6208	176	203	216	225	227
432PSL6210	220	260	275	280	287
432PSL6212	225	260	276	280	300
433PSL6216	290	343	366	375	387
433PSL6220	315	362	385	400	417

[General notes on page 42](#) may apply to this page.
[See available modifications](#) on pages 38–41.

RATINGS

*NEMA is a trademark or trade name of National Electrical Manufacturers Association and is not owned by or under the control of Marathon Electric LLC .

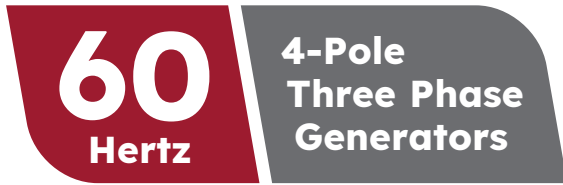

**208Y or 416Y Volts
240 or 120 Volts Delta
416Y Volts**

**1800 RPM
NEMA®* Class H Insulation
40°C Ambient
0.8 Power Factor Lagging
Includes PMG Excitation**

Regulator: Includes DVR®2400, except 572-574 frame RSL models which include PM500.

MAGNAMAX® Standard Models

Base Model	kW Rating @ Designated NEMA Rise				
	Continuous			Standby	
	NEMA B 80°C R/R	NEMA F 105°C R/R	NEMA H 125°C R/R	NEMA F 130°C R/R	NEMA H 150°C R/R
Random Wound Coil Designs, 12 Lead Reconnectable with Bus Bars Standard, 208Y/416Y					
572RSL6425	385	435	440	440	450
572RSL6427	400	445	470	475	505
572RSL6429	450	510	525	525	535
572RSL6431	460	525	555	565	600
573RSL6433	570	650	685	700	725
573RSL6435	590	680	720	725	725
574RSL6437	630	725	770	785	825
Random Wound Coil Designs, 4 Bars, 416Y Only					
574RSL6438	675	770	820	835	885
575RSL4044	760	890	950	975	1040
741RSL4044	810	920	970	1000	1020
740RSL4046	880	1020	1090	1110	1180
742RSL4048	950	1100	1160	1180	1250
742RSL4050	1110	1270	1340	1370	1410
743RSL4052	1400	1610	1610	1610	1620
744RSL4054	1420	1680	1800	1840	1840
744RSL4056	1520	1780	1900	1950	2000
744RSL4057	1640	1920	2050	2090	2240
764RSL4063	1730	1950	2080	2170	2300
Form Wound Coil Designs, 4 Bars, 416Y Only					
573FSL4402	390	460	500	500	520
574FSL4404	490	590	650	650	670
742FSL4408	690	870	950	980	1020
743FSL4410	780	950	1040	1060	1110
743FSL4412	890	1080	1150	1170	1190
744FSL4060	1190	1380	1440	1440	1440
744FSL4062	1510	1750	1830	1830	1830
744FSL4414	1620	1880	2010	2040	2120

MAGNAPOWER® Standard Models

All 860 & 1000 frame generators have 4 bus bars, with the capability of differential protection.

Base Model	kW Rating @ Designated NEMA Rise				
	Continuous			Standby	
	NEMA B 80°C R/R	NEMA F 105°C R/R	NEMA H 125°C R/R	NEMA F 130°C R/R	NEMA H 150°C R/R
Random Wound Coil Designs, 416Y Only					
862RSL86006	2260	2580	2800	2800	2940
1020RDL1109	2400	2900	3100	3100	3300
1020RDL1111	2600	3000	3200	3300	3400
Form Wound Coil Designs, 416Y Only					
1020FDL1100	1920	2190	2280	2320	2320
1020FDL1102	2040	2250	2500	2500	2500
1020FDL1104	2200	2510	2610	2660	2710
1020FDL1106	2450	2680	2750	2760	2780
863FSL86056	2160	2460	2700	2700	2830
1020FDL1108	2550	2850	2850	2850	2850
1030FDL1110	2620	3060	3210	3250	3250

General notes on page 42 may apply to this page.
See available modifications on pages 38.

60 Hertz **4-Pole Three Phase Generators**

220Y or 440Y Volts

1800 RPM
NEMA®* Class H Insulation
40°C Ambient
0.8 Power Factor Lagging
Shunt (Non-PMG) Excitation
SE350E AVR

MAGNAPLUS® Standard Models

Base Model	kW Rating @ Designated NEMA Rise				
	Continuous			Standby	
	NEMA B 80°C R/R	NEMA F 105°C R/R	NEMA H 125°C R/R	NEMA F 130°C R/R	NEMA H 150°C R/R
12 Lead Reconnectable with Link Board as Standard					
282PSL1704	12.5	15	16.2	16.2	17.5
282PSL1705	17	20	21	21	22
283PSL1706	21	24	26	26	28
283PSL1707	24	29	31	31	34
284PSL1708	30	32	35	35	40
284PSL1742	32	36	40	40	43
285PSL1700	37	41	45	45	48
286PSL1701	43	50	56	56	60
361PSL1600	37	42	45	45	47
361PSL1601	48	53	58	58	61
361PSL1602	56	63	68	68	71
362PSL1604	68	76	84	84	89
362PSL1606	82	92	102	102	107
363PSL1607	105	115	130	130	140
364PSL1608	125	145	155	155	160
364PSL1609	135	160	180	180	185
431PSL6202	125	143	151	153	160
431PSL6204	143	167	177	180	185
431PSL6206	172	200	212	220	226
431PSL6208	180	210	221	225	233
432PSL6210	221	261	278	283	292
432PSL6212	227	266	285	290	300
433PSL6216	290	348	372	380	395
433PSL6220	317	375	397	410	423

[General notes on page 42](#) may apply to this page.
[See available modifications](#) on pages 38–41.

*NEMA is a trademark or trade name of National Electrical Manufacturers Association and is not owned by or under the control of Marathon Electric LLC .

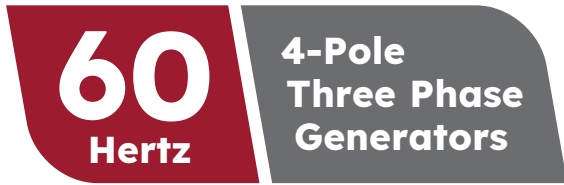

**220Y or 440Y Volts
440Y Volts**

**1800 RPM
NEMA®* Class H Insulation
40°C Ambient
0.8 Power Factor Lagging
Includes PMG Excitation**

Regulator: Includes DVR®2400, except 572-574 frame RSL models which include PM500.

MAGNAMAX® Standard Models

Base Model	kW Rating @ Designated NEMA Rise				
	Continuous			Standby	
	NEMA B 80°C R/R	NEMA F 105°C R/R	NEMA H 125°C R/R	NEMA F 130°C R/R	NEMA H 150°C R/R
Random Wound Coil, 12 Lead Reconnectable with Bus Bars Standard, 220Y/440Y					
572RSL6425	400	455	465	465	465
572RSL6427	410	460	485	500	520
572RSL6429	470	535	560	560	560
572RSL6431	480	545	580	590	625
573RSL6433	595	680	725	730	765
573RSL6435	620	715	760	765	765
574RSL6437	660	760	805	820	875
Random Wound Coil Designs, 4 Bars, 440Y Only					
574RSL6438	705	810	860	875	930
575RSL4044	785	925	995	1010	1090
741RSL4044	840	960	1020	1030	1070
740RSL4046	915	1070	1140	1160	1240
742RSL4048	1000	1140	1220	1240	1280
742RSL4050	1160	1340	1420	1450	1500
743RSL4052	1420	1680	1710	1710	1710
744RSL4054	1460	1750	1880	1920	1920
744RSL4056	1590	1860	1990	2030	2100
744RSL4057	1690	1990	2140	2180	2340
764RSL4063	1830	2070	2210	2300	2440
Form Wound Coil Designs, 4 Bars, 440Y Only					
573FSL4402	410	480	530	530	550
574FSL4404	520	620	690	690	710
742FSL4408	730	920	1010	1030	1080
743FSL4410	830	1010	1100	1120	1170
743FSL4412	940	1150	1210	1240	1260
744FSL4060	1210	1400	1460	1460	1460
744FSL4062	1530	1780	1860	1860	1860
744FSL4414	1680	1960	2100	2140	2180

[General notes on page 42](#) may apply to this page.
[See available modifications](#) on pages 38.



**4-Pole
Three Phase
Broad Range
Generators**

**208Y-240Y or
416Y-480Y Volts
240 or 120 Volts Delta**

**1800 RPM
NEMA®* Class H Insulation
40°C Ambient
0.8 Power Factor Lagging
Shunt (Non-PMG) Excitation
SE350E AVR**

MAGNAPLUS® Standard Models

Base Model	kW Rating @ Designated NEMA Rise				
	Continuous			Standby	
	NEMA B 80°C R/R	NEMA F 105°C R/R	NEMA H 125°C R/R	NEMA F 130°C R/R	NEMA H 150°C R/R
12 Lead Reconnectable with Link Board as Standard					
282PSL1704	12.5	15	16	16	17.5
282PSL1705	17	20	21	21	22
283PSL1706	21	23	25	25	28
283PSL1707	24	28	30	30	33
284PSL1708	30	32	35	35	40
284PSL1742	32	36	40	40	42
285PSL1700	36	40	45	45	47
286PSL1701	42	50	55	55	58
361PSL1600	35	40	42	42	45
361PSL1601	45	50	55	55	58
361PSL1602	53	60	65	65	68
362PSL1604	65	72	80	80	85
362PSL1606	80	90	100	100	105
363PSL1607	100	110	125	125	135
364PSL1608	125	140	155	155	160
364PSL1609	125	140	160	160	165
431PSL6202	125	140	147	151	155
431PSL6204	142	165	175	176	182
431PSL6206	165	191	202	210	217
431PSL6208	176	203	216	225	227
432PSL6210	211	255	275	280	287
432PSL6212	225	260	276	280	300
433PSL6216	280	342	366	375	387
433PSL6220	310	362	385	400	417

[General notes on page 42](#) may apply to this page.
[See available modifications](#) on pages 38–41.

*NEMA is a trademark or trade name of National Electrical Manufacturers Association and is not owned by or under the control of Marathon Electric LLC .

60
Hertz

**4-Pole
Three Phase
Broad Range
Generators**

**208Y-240Y or
416Y-480Y Volts
240 or 120 Volts Delta**

**1800 RPM
NEMA®* Class H Insulation
40°C Ambient
0.8 Power Factor Lagging
Includes PMG Excitation
PM500**

MAGNAMAX® Standard Models

Base Model	kW Rating @ Designated NEMA Rise				
	Continuous			Standby	
	NEMA B 80°C R/R	NEMA F 105°C R/R	NEMA H 125°C R/R	NEMA F 130°C R/R	NEMA H 150°C R/R
12 Lead Reconnectable with Bus Bars Standard					
572RSL6425	380	435	440	440	450
572RSL6427	400	445	470	475	505
572RSL6429	445	510	525	525	535
572RSL6431	460	525	555	565	600
573RSL6433	570	650	685	700	725
573RSL6435	585	680	720	725	725
574RSL6437	630	725	770	785	825

[General notes on page 42](#) may apply to this page.
[See available modifications](#) on pages 38.

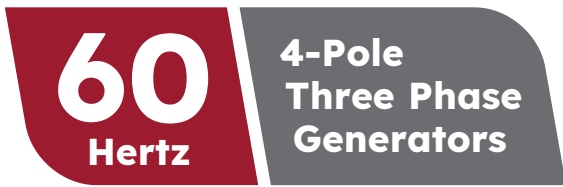

200Y or 400Y Volts

**1800 RPM
NEMA®* Class H Insulation
40°C Ambient
0.8 Power Factor Lagging
Shunt (Non-PMG) Excitation
SE350E AVR**

MAGNAPLUS® Standard Models

Base Model	kW Rating @ Designated NEMA Rise				
	Continuous			Standby	
	NEMA B 80°C R/R	NEMA F 105°C R/R	NEMA H 125°C R/R	NEMA F 130°C R/R	NEMA H 150°C R/R
12 Lead Reconnectable with Link Board as Standard					
282PSL1704	12.1	14.3	15.3	15.4	18.1
282PSL1705	16.1	19.1	20	20	21
283PSL1706	20	22	24	24	27
283PSL1707	23	27	29	29	32
283PSL1708	29	31	34	34	39
284PSL1742	31	35	39	39	40
285PSL1700	35	39	43	43	45
286PSL1701	40	48	53	53	56
361PSL1600	34	38	40	40	43
361PSL1601	43	48	53	53	55
361PSL1602	51	58	63	63	65
362PSL1604	63	69	76	76	81
362PSL1606	76	86	96	96	101
363PSL1607	96	106	121	121	131
364PSL1608	120	135	150	150	155
364PSL1609	131	149	169	169	174
431PSL6202	121	136	142	146	151
431PSL6204	139	161	171	172	178
431PSL6206	164	184	194	202	209
431PSL6208	172	198	210	217	221
432PSL6210	217	253	268	273	282
432PSL6212	219	252	267	273	289
433PSL6216	286	337	359	367	380
433PSL6220	305	350	372	385	403

[General notes on page 42](#) may apply to this page.
[See available modifications](#) on pages 38–41.

RATINGS

*NEMA is a trademark or trade name of National Electrical Manufacturers Association and is not owned by or under the control of Marathon Electric LLC .

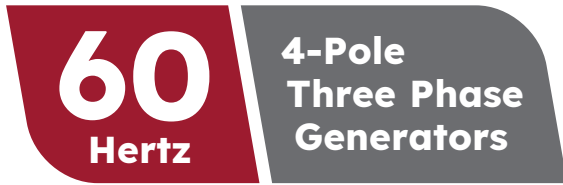

200Y or 400Y Volts
400Y Volts

1800 RPM
NEMA®* Class H Insulation
40°C Ambient
0.8 Power Factor Lagging
Includes PMG Excitation

Regulator: Includes DVR®2400, except 572-574 frame RSL models which include PM500.

MAGNAMAX® Standard Models

Base Model	kW Rating @ Designated NEMA Rise				
	Continuous			Standby	
	NEMA B 80°C R/R	NEMA F 105°C R/R	NEMA H 125°C R/R	NEMA F 130°C R/R	NEMA H 150°C R/R
Random Wound Coil, 12 Lead Reconnectable with Bus Bars Standard, 200Y/400Y					
572RSL6425	369	419	422	422	428
572RSL6427	382	427	441	443	459
572RSL6429	434	492	500	500	506
572RSL6431	444	507	524	529	547
573RSL6433	550	626	644	652	666
573RSL6435	570	656	677	680	680
574RSL6437	612	701	725	733	754
Random Wound Coil Designs, 4 Bars, 400Y Only					
574RSL6438	651	741	768	776	802
575RSL4044	742	863	896	909	943
741RSL4044	779	884	911	927	938
740RSL4046	856	987	1025	1035	1072
742RSL4048	928	1069	1102	1112	1149
742RSL4050	1070	1221	1259	1275	1296
743RSL4052	1351	1552	1552	1552	1558
744RSL4054	1394	1640	1706	1727	1727
744RSL4056	1480	1722	1833	1879	1934
744RSL4057	1600	1863	1988	2028	2165
764RSL4063	1655	1870	1995	2070	2195
Form Wound Coil Designs, 4 Bars, 400Y Only					
573FSL4402	380	440	480	480	500
574FSL4404	480	570	630	630	650
742FSL4408	670	830	920	940	980
743FSL4410	750	920	1000	1020	1060
743FSL4412	850	1040	1100	1130	1150
744FSL4060	1159	1336	1368	1368	1368
744FSL4062	1475	1706	1750	1750	1750
744FSL4414	1575	1820	1950	1980	2050

MAGNAPOWER® Standard Models

All 860 & 1000 frame generators have 4 bus bars, with the capability of differential protection.

Base Model	Continuous			Standby	
	NEMA B 80°C R/R	NEMA F 105°C R/R	NEMA H 125°C R/R	NEMA F 130°C R/R	NEMA H 150°C R/R
Random Wound Coil Designs, 400Y Only					
862RSL86006	2170	2500	2690	2690	2830
1020RDL1109	2250	2750	2950	2950	3150
1020RDL1111	2450	2850	3050	3150	3250
Form Wound Coil Designs, 400Y Only					
1020FDL1100	1876	2132	2220	2260	2260
1020FDL1102	1990	2190	2430	2430	2430
1020FDL1104	2150	2445	2540	2590	2635
1020FDL1106	2440	2590	2640	2660	2680
863FSL86056	2080	2365	2600	2600	2730
1020FDL1108	2540	2740	2740	2740	2740
1030FDL1110	2580	3030	3100	3125	3125

General notes on page 42 may apply to this page.
See available modifications on pages 38.



*NEMA is a trademark or trade name of National Electrical Manufacturers Association and is not owned by or under the control of Marathon Electric LLC.

60
Hertz

**4-Pole
Three Phase**
(Std. 480 Volt Designs)
Generators

**190Y or 380Y Volts
220 or 110 Volts Delta**

1800 RPM
NEMA®* Class H Insulation
40°C Ambient
0.8 Power Factor Lagging
Shunt (Non-PMG) Excitation
SE350E AVR

MAGNAPLUS® Standard Models

Base Model	kW Rating @ Designated NEMA Rise				
	Continuous			Standby	
	NEMA B 80°C R/R	NEMA F 105°C R/R	NEMA H 125°C R/R	NEMA F 130°C R/R	NEMA H 150°C R/R
12 Lead Reconnectable with Link Board as Standard					
282PSL1704	11.5	13.5	14.5	14.6	16
282PSL1705	15	18	19	19	20
283PSL1706	19	21	23	23	26
283PSL1707	22	26	27	27	30
284PSL1708	27	29	32	32	37
284PSL1742	29	33	37	37	38
285PSL1700	33	37	41	41	43
286PSL1701	38	46	50	50	53
361PSL1600	32	36	38	38	41
361PSL1601	41	45	50	50	52
361PSL1602	48	55	60	60	62
362PSL1604	60	65	72	72	77
362PSL1606	72	81	90	90	95
363PSL1607	90	100	115	115	125
364PSL1608	115	130	140	140	145
364PSL1609	125	140	160	160	165
431PSL6202	115	130	135	140	145
431PSL6204	136	155	165	167	172
431PSL6206	156	176	185	191	200
431PSL6208	167	192	203	207	213
432PSL6210	213	245	260	265	275
432PSL6212	212	243	256	265	275
433PSL6216	281	330	350	357	370
433PSL6220	292	335	355	367	385

[General notes on page 42](#) may apply to this page.
[See available modifications](#) on pages 38-41.

*NEMA is a trademark or trade name of National Electrical Manufacturers Association and is not owned by or under the control of Marathon Electric LLC .

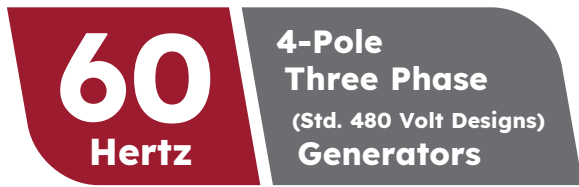

**190Y or 380Y Volts
220 or 110 Volts Delta
380Y Volts**

**1800 RPM
NEMA®* Class H Insulation
40°C Ambient
0.8 Power Factor Lagging
Includes PMG Excitation**

Regulator: Includes DVR®2400, except 572-574 frame RSL models which include PM500.

MAGNAMAX® Standard Models

Base Model	kW Rating @ Designated NEMA Rise				
	Continuous			Standby	
	NEMA B 80°C R/R	NEMA F 105°C R/R	NEMA H 125°C R/R	NEMA F 130°C R/R	NEMA H 150°C R/R
Random Wound Coil Designs, 12 Lead Reconnectable with Bus Bars Standard, 190Y/380Y					
572RSL6425	350	400	400	400	400
572RSL6427	360	405	405	405	405
572RSL6429	415	470	470	470	470
572RSL6431	425	485	485	485	485
573RSL6433	525	595	595	595	595
573RSL6435	545	625	625	625	625
574RSL6437	590	670	670	670	670
Random Wound Coil Designs, 4 Bars, 380Y Only					
574RSL6438Ⓚ	620	705	705	705	705
575RSL4044	720	830	830	830	830
741RSL4044	740	840	840	840	840
740RSL4046	825	945	945	945	945
742RSL4048	900	1030	1030	1030	1030
742RSL4050	1020	1160	1160	1160	1160
743RSL4052	1290	1480	1480	1480	1480
744RSL4054	1360	1590	1590	1590	1590
744RSL4056	1430	1650	1750	1790	1850
744RSL4057	1550	1790	1910	1950	2070
764RSL4063	1580	1790	1910	1970	2090
Form Wound Coil Designs, 4 Bars, 380Y Only					
573FSL4402	360	420	460	460	480
574FSL4404	450	540	590	590	610
742FSL4408	630	790	870	890	930
743FSL4410	710	870	950	970	1010
743FSL4412	810	990	1050	1070	1090
744FSL4060	1120	1280	1280	1280	1280
744FSL4062	1430	1650	1650	1650	1650
744FSL4414	1520	1750	1860	1900	1960

See dedicated 380 Volt generators on page 16 for improved ratings and transient performance.

MAGNAPOWER® Standard Models

All 860 & 1000 frame generators have 4 bus bars, with the capability of differential protection.

Base Model	kW Rating @ Designated NEMA Rise				
	Continuous			Standby	
	NEMA B 80°C R/R	NEMA F 105°C R/R	NEMA H 125°C R/R	NEMA F 130°C R/R	NEMA H 150°C R/R
Random Wound Coil Designs, 6 Lead, 380Y Only					
862RSL86006	2060	2360	2560	2560	2690
1020RDL1109	2100	2600	2800	2800	3000
1020RDL1111	2300	2700	2900	3000	3100
Form Wound Coil Designs, 6 Lead, 380Y Only					
1020FDL1100	1820	2060	2140	2180	2180
1020FDL1102	1930	2115	2340	2340	2340
1020FDL1104	2090	2360	2450	2500	2540
1020FDL1106	2430	2510	2525	2550	2570
863FSL86056	2000	2275	2500	2500	2625
1020FDL1108	2530	2600	2600	2600	2600
1030FDL1110	2540	3000	3000	3000	3000

General notes on page 42 may apply to this page.
See available modifications on pages 38..



*NEMA is a trademark or trade name of National Electrical Manufacturers Association and is not owned by or under the control of Marathon Electric LLC.

**60
Hertz****4-Pole
Three Phase
Dedicated Design
Generators****380Y/219 Volts****1800 RPM
NEMA®* Class H Insulation
40°C Ambient
0.8 Power Factor Lagging
DVR®2400 AVR w/ PMG Excitation****MAGNAMAX®** Standard Models

Base Model	kW Rating @ Designated NEMA Rise				
	Continuous			Standby	
	NEMA B 80°C R/R	NEMA F 105°C R/R	NEMA H 125°C R/R	NEMA F 130°C R/R	NEMA H 150°C R/R
Random wound coil designs, 4 Bars					
572RSL4160	355	425	450	450	480
572RSL4162	425	485	500	500	525
573RSL4165	615	735	780	785	800
574RSL4166	670	800	830	830	900
574RSL4168	715	855	910	915	965
Random wound coil designs, 4 Bars					
741RSL4170	850	1015	1065	1085	1085
742RSL4172	1000	1200	1260	1300	1300
743RSL4174	1260	1550	1650	1700	1700
744RSL4176	1500	1850	1950	2000	2000
764RSL4177	1750	2000	2100	2150	2250

**60
Hertz****4-Pole
Three Phase
Dedicated Design
Generators****400Y/231 Volts****1800 RPM
NEMA Class H Insulation
40°C Ambient
0.8 Power Factor Lagging
DVR®2400 AVR w/ PMG Excitation****MAGNAMAX®** Standard Models

Base Model	kW Rating @ Designated NEMA Rise				
	Continuous			Standby	
	NEMA B 80°C R/R	NEMA F 105°C R/R	NEMA H 125°C R/R	NEMA F 130°C R/R	NEMA H 150°C R/R
Random wound coil designs, 4 Bars					
572RSL4160	350	415	440	440	465
572RSL4162	385	436	450	450	490
573RSL4165	507	605	623	623	680
574RSL4166	620	737	760	800	830
574RSL4168	665	793	843	850	895
Random wound coil designs, 4 Bars					
741RSL4170	865	1030	1080	1100	1100
742RSL4172	1000	1200	1260	1300	1300
743RSL4174	1310	1600	1700	1750	1750
744RSL4176	1500	1850	1960	2000	2000
764RSL4177	1750	2000	2100	2150	2250

[General notes on page 42](#) may apply to this page.
[See available modifications](#) on pages 38..

*NEMA is a trademark or trade name of National Electrical Manufacturers Association and is not owned by or under the control of Marathon Electric LLC .

60 Hertz

4-Pole Three Phase Dedicated Design Generators

600Y/346 Volts

1800 RPM
NEMA®* Class H Insulation
40°C Ambient
0.8 Power Factor Lagging

MAGNAPLUS® Standard Models

SE350E AVR w/ Shunt
(Non-PMG) Excitation

Base Model	kW Rating @ Designated NEMA Rise				
	Continuous			Standby	
	NEMA B 80°C R/R	NEMA F 105°C R/R	NEMA H 125°C R/R	NEMA F 130°C R/R	NEMA H 150°C R/R
4 Lead with Link Board as Standard					
282PSL5249	17	20	21	21	22
283PSL5250	22	25	27	27	29
283PSL5251	25	30	33	33	35
284PSL5252	30	32	35	35	40
284PSL5253	32	36	40	40	45
361PSL1633	49	55	60	60	65
361PSL1634	58	65	70	70	76
362PSL1635	75	84	90	90	95
362PSL1636	80	96	105	105	113
363PSL1658	110	125	135	135	150
431PSL6240	125	140	150	155	160
431PSL6242	140	170	175	180	190
431PSL6243	180	210	225	230	240
432PSL6246	230	275	300	305	310
433PSL6248	310	375	400	410	430

MAGNAMAX® Standard Models

DVR®2400 AVR w/ PMG Excitation

Base Model	kW Rating @ Designated NEMA Rise				
	Continuous			Standby	
	NEMA B 80°C R/R	NEMA F 105°C R/R	NEMA H 125°C R/R	NEMA F 130°C R/R	NEMA H 150°C R/R
Random wound coil designs, 4 Bars					
572RSS4270	420	475	500	510	540
572RSS4272	485	575	600	600	640
573RSS4274	565	640	700	700	725
573RSS4276	575	685	725	725	780
574RSS4278	700	825	875	875	900
574RSS4280	800	900	960	960	980
Random wound coil designs, 4 Bars					
742RSS4286	960	1100	1180	1200	1200
743RSS4288	1120	1330	1330	1400	1400
743RSS4290	1300	1550	1650	1700	1700
744RSS4292	1500	1850	1950	2000	2000
744RSS4293	1600	2000	2100	2150	2250
764RSS4295	1850	2100	2300	2400	2400

MAGNAPOWER® Standard Models

DVR®2400 AVR w/ PMG Excitation

All 860 & 1000 frame generators have 4 bus bars, with the capability of differential protection.

Base Model	kW Rating @ Designated NEMA Rise				
	Continuous			Standby	
	NEMA B 80°C R/R	NEMA F 105°C R/R	NEMA H 125°C R/R	NEMA F 130°C R/R	NEMA H 150°C R/R
4 Bus Bars, Form Wound Coils designs, 6 Leads					
1020FDS1120	1750	2000	2250	2250	2250
1020FDS1122	2000	2250	2500	2500	2500
1020FDS1124	2250	2500	2800	2800	2800
1030FDS1126	2500	2800	3000	3000	3000
1030FDS1128	2500	3000	3250	3250	3250

General notes on page 42 may apply to this page.
See available modifications on pages 38-41.

60 Hertz 4-Pole Single Phase Generators

240/120 Volts
480/240 Volts
120 Volts Delta

1800 RPM
NEMA® Class H Insulation
40°C Ambient

MAGNAPLUS® Standard Models

SE350E AVR w/ Shunt (Non-PMG) Excitation

Base Model	kW Rating @ Designated NEMA Rise									
	0.8 Power Factor Lagging					1.0 Power Factor				
	Continuous			Standby		Continuous			Standby	
	NEMA B 80°C R/R	NEMA F 105°C R/R	NEMA H 125°C R/R	NEMA F 130°C R/R	NEMA H 150°C R/R	NEMA B 80°C R/R	NEMA F 105°C R/R	NEMA H 125°C R/R	NEMA F 130°C R/R	NEMA H 150°C R/R
12 Lead Reconnectable with Link Board as Standard										
282PSL1704	8	10	10.5	10.5	11	10.5	12.5	14	14	15
282PSL1705	11	12.5	13.5	13.5	14	14	16	17.5	17.5	18.5
283PSL1706	13	15	16	16	17	17	20	21	21	23
283PSL1707	15	17	18	18	20	19	22	25	25	26
284PSL1708	19	21	23	23	25	25	28	30	30	32
284PSL1742	20	23	25	25	27	25	30	32	32	35
285PSL1700	21	25	28	28	30	30	35	37	37	40
286PSL1701	24	28	32	32	34	32	38	42	42	45
361PSL1600	25	28	30	30	32	31	36	38	39	40
361PSL1601	30	33	35	35	37	38	42	45	45	48
361PSL1602	35	40	42	42	45	45	51	55	55	60
362PSL1604	41	47	50	51	54	53	61	66	66	71
362PSL1606	49	55	59	60	64	66	76	78	79	85
363PSL1607	60	66	72	73	78	80	90	95	97	100
364PSL1608	65	80	85	85	95	90	100	105	110	115
364PSL1609	75	90	95	95	105	100	110	120	125	130
431PSL6202	77	90	95	96	100	96	115	120	121	125
431PSL6204	85	100	106	107	110	106	125	133	135	140
431PSL6206	105	120	130	132	135	131	150	165	166	175
431PSL6208	105	120	130	132	136	131	150	165	166	175
432PSL6210	125	147	158	161	165	156	185	200	201	206
432PSL6212	125	147	158	161	165	156	185	200	201	206
433PSL6216	150	175	190	193	200	190	220	240	241	250
433PSL6220	150	175	190	193	200	190	220	240	241	250

MAGNAMAX® Standard Models

PM500 AVR w/ PMG Excitation

Base Model	kW Rating @ Designated NEMA Rise									
	0.8 Power Factor Lagging					1.0 Power Factor				
	Continuous			Standby		Continuous			Standby	
	NEMA B 80°C R/R	NEMA F 105°C R/R	NEMA H 125°C R/R	NEMA F 130°C R/R	NEMA H 150°C R/R	NEMA B 80°C R/R	NEMA F 105°C R/R	NEMA H 125°C R/R	NEMA F 130°C R/R	NEMA H 150°C R/R
12 Lead Reconnectable with Bus Bars Standard										
572RSL6425	167	198	209	209	222	209	248	261	261	278
572RSL6427	194	220	227	227	246	242	275	283	283	308
572RSL6429	196	235	246	246	268	245	294	308	308	336
572RSL6431	213	253	264	264	284	267	316	330	330	355
573RSL6433	251	299	308	308	337	314	374	385	385	421
573RSL6435	257	312	330	330	356	322	391	413	413	446
574RSL6437	295	352	363	363	396	369	440	454	454	495

General notes on page 42 may apply to this page.
See available modifications on pages 38-41.

*NEMA is a trademark or trade name of National Electrical Manufacturers Association and is not owned by or under the control of Marathon Electric LLC.

60 Hertz

4-Pole Single Phase Dedicated Generators

240/120 or 120 Volts

1800 RPM
NEMA®* Class H Insulation
40°C Ambient

SE350EL AVR w/ Shunt (Non-PMG) Excitation

MAGNAPLUS® Standard Models

Base Model	kW Rating @ Designated NEMA Rise									
	0.8 Power Factor Lagging					1.0 Power Factor				
	Continuous			Standby		Continuous			Standby	
	NEMA B 80°C R/R	NEMA F 105°C R/R	NEMA H 125°C R/R	NEMA F 130°C R/R	NEMA H 150°C R/R	NEMA B 80°C R/R	NEMA F 105°C R/R	NEMA H 125°C R/R	NEMA F 130°C R/R	NEMA H 150°C R/R
4 Lead with Link Board as Standard										
282PSL1714	7	7.7	8.4	8.5	9	10.5	12	13	13	13.5
282PSL1715	10	11	12	12	12.5	15	17	18	18	20
282PSL1716	12	14	15	15	16	18	20	22	22	25
283PSL1717	15	17	18.5	18.5	20	22	25	27	27	30
283PSL1718	17	20	22	22	23	26	30	32	32	35
284PSL1750	23	26	27	27	30	34	38	41	41	45
361PSL1613	38	43	47	47	50	50	55	60	60	65
362PSL1615	48	54	59	60	65	65	70	75	75	100
363PSL1617	50	58	66	66	70	75	90	100	100	105
431PSL6224	80	90	100	100	110	130	145	155	155	165
431PSL6226	85	100	110	110	115	135	155	175	175	185
432PSL6228	125	145	155	155	170	170	195	210	210	225

Pancake Standard Models

NEMA®* Class F Insulation

Pancake generators are designed for space-critical single bearing applications.
Double bearing models not available.
CSA models are SAE 5, CSB models are SAE 4.

Base Model	kW Rating @ Designated NEMA Rise									
	0.8 Power Factor Lagging					1.0 Power Factor				
	Continuous			Standby		Continuous			Standby	
	NEMA B 80°C R/R	NEMA F 105°C R/R	NEMA H 125°C R/R	NEMA F 130°C R/R	NEMA H 150°C R/R	NEMA B 80°C R/R	NEMA F 105°C R/R	NEMA H 125°C R/R	NEMA F 130°C R/R	NEMA H 150°C R/R
331CSA3018	4.5	5	N/A	5.5	N/A	8	8.5	N/A	9	N/A
332CSA3020	6	6.5	N/A	7	N/A	10	10.5	N/A	11	N/A
333CSA3024	9	10	N/A	10	N/A	12.5	15	N/A	16.5	N/A
334CSA/B3028	11.5	13	N/A	14.5	N/A	17	20	N/A	22.5	N/A

[General notes on page 42](#) may apply to this page.
[See available modifications](#) on pages 38–41.

**60
Hertz****4-Pole
Three Phase
Medium Voltage
Generators****4160Y/2402 Volts
2402 Volts Delta****1800 RPM
NEMA®* Class H Insulation
40°C Ambient
0.8 Power Factor Lagging
DVR2400 AVR w/ PMG Excitation****MAGNAMAX®** Standard Models

Base Model	kW Rating @ Designated NEMA Rise				
	Continuous			Standby	
	NEMA B 80°C R/R	NEMA F 105°C R/R	NEMA H 125°C R/R	NEMA F 130°C R/R	NEMA H 150°C R/R
6 Lead, Form Wound Coils and VPI Insulation Systems					
573FSM4352	315	400	415	415	460
573FSM4354	350	450	500	500	530
574FSM4356	465	600	625	625	700
574FSM4358	550	710	760	760	840
741FSM4360①	730	900	925	925	930
742FSM4364①	925	1120	1200	1200	1200
742FSM4366①	1120	1360	1450	1450	1450
743FSM4368①	1240	1520	1600	1600	1610
743FSM4370①	1370	1680	1800	1800	1800
744FSM4374①	1525	1875	2050	2050	2050
744FSM4375①	1800	2150	2320	2320	2320
764FSM4377①	2000	2250	2400	2500	2600

MAGNAPOWER® Standard Models

All 1000 frame generators have 4 bus bars, with the capability of differential protection.

Base Model	Continuous			Standby	
	NEMA B 80°C R/R	NEMA F 105°C R/R	NEMA H 125°C R/R	NEMA F 130°C R/R	NEMA H 150°C R/R
6 Lead, Form Wound Coils and VPI Insulation Systems					
1020FDM1182①	2250	2500	2800	2800	2800
1020FDM1184①	2400	2800	3000	3000	3000
1030FDM1186①	2650	3000	3000	3000	3000
1030FDM1188①	2650	3000	3300	3350	3350
1030FDM1190①	2800	3250	3420	3500	3500
1030FDM1192①	2920	3340	3650	3680	3680
Consult factory for extended ratings.					

[General notes on page 42](#) may apply to this page.[See available modifications](#) on pages 38.

Medium voltage sensing potential transformers (P/Ts) are not included. For three-phase sensing, a three-phase PT is required. Price adder may apply.

① All 740, 760 and 1000 frame generators on this page have 100 ohm platinum winding RTDs as standard equipment.

*NEMA is a trademark or trade name of National Electrical Manufacturers Association and is not owned by or under the control of Marathon Electric LLC.

60 Hertz

4-Pole Three Phase Medium Voltage Generators

1800 RPM
 NEMA®* Class H Insulation
 40°C Ambient
 0.8 Power Factor Lagging
 DVR®2400 AVR w/PMG Excitation

MAGNAMAX® Standard Models

2400Y/1386 Volts
1386 Volts Delta

Base Model	kW Rating @ Designated NEMA Rise				
	Continuous			Standby	
	NEMA B 80°C R/R	NEMA F 105°C R/R	NEMA H 125°C R/R	NEMA F 130°C R/R	NEMA H 150°C R/R
6 Lead, Form Wound Coils and VPI Insulation Systems					
573FSM4304	315	400	415	415	450
573FSM4306	350	450	500	500	530
574FSM4308	450	550	575	600	600
574FSM4310	525	660	725	735	750
741FSM4314Ⓢ	700	875	890	900	900
742FSM4316Ⓢ	925	1090	1175	1200	1200
742FSM4318Ⓢ	1075	1270	1360	1400	1400
743FSM4320Ⓢ	1180	1410	1470	1550	1550
743FSM4322Ⓢ	1370	1630	1780	1800	1800

MAGNAPOWER® Standard Models All 1000 frame generators have 4 bus bars, with the capability of differential protection.

Base Model	kW Rating @ Designated NEMA Rise				
	Continuous			Standby	
	NEMA B 80°C R/R	NEMA F 105°C R/R	NEMA H 125°C R/R	NEMA F 130°C R/R	NEMA H 150°C R/R
6 Lead, Form Wound Coils and VPI Insulation Systems					
1020FDM5320Ⓢ	1750	2000	2100	2100	2100
1020FDM5322Ⓢ	2000	2300	2400	2400	2400
1020FDM5324Ⓢ	2250	2570	2700	2700	2700
1030FDM5326Ⓢ	2500	2860	3000	3000	3000

MAGNAMAX® Standard Models

3300Y/1905 Volts
1905 Volts Delta

Base Model	kW Rating @ Designated NEMA Rise				
	Continuous			Standby	
	NEMA B 80°C R/R	NEMA F 105°C R/R	NEMA H 125°C R/R	NEMA F 130°C R/R	NEMA H 150°C R/R
6 Lead, Form Wound Coils and VPI Insulation Systems					
573FSM4326	315	400	415	415	450
573FSM4328	350	450	500	500	530
574FSM4330	465	600	625	625	675
741FSM4334Ⓢ	700	850	900	900	925
742FSM4336Ⓢ	950	1120	1200	1200	1280
742FSM4338Ⓢ	1100	1310	1380	1400	1400
743FSM4340Ⓢ	1250	1470	1550	1550	1570
743FSM4342Ⓢ	1370	1625	1800	1800	1800
744FSM4344Ⓢ	1500	1850	2000	2000	2000
744FSM4345Ⓢ	1800	2150	2320	2320	2320
764FSM4347Ⓢ	2000	2250	2400	2500	2600

MAGNAPOWER® Standard Models All 1000 frame generators have 4 bus bars, with the capability of differential protection.

Base Model	kW Rating @ Designated NEMA Rise				
	Continuous			Standby	
	NEMA B 80°C R/R	NEMA F 105°C R/R	NEMA H 125°C R/R	NEMA F 130°C R/R	NEMA H 150°C R/R
6 Lead, Form Wound Coils and VPI Insulation Systems					
1020FDM5332Ⓢ	2000	2300	2400	2400	2400
1020FDM5334Ⓢ	2250	2570	2700	2700	2700
1020FDM5336Ⓢ	2500	2860	3000	3000	3000

General notes on page 42 may apply to this page.
 See available modifications on pages 38.

Medium voltage sensing potential transformers (P/Ts) are not included. For three-phase sensing, a three-phase PT is required. Price adder may apply.
 j All 740, 760 and 1000 frame generators on this page have 100 ohm platinum winding RTDs as standard equipment.

60 Hertz

4-Pole Three Phase Medium Voltage Generators

6300Y/3637 Volts or 3637 Volts Delta

1800 RPM
40°C Ambient
0.8 Power Factor Lagging
DVR®2400 AVR w/ PMG Excitation

MAGNAMAX® Standard Models

NEMA®* Class H Insulation

NOTE: 570, 740 & 760 Frame units MUST employ solidly grounded neutral.

Base Model	kW Rating @ Designated NEMA Rise				
	Continuous			Standby	
	NEMA B 80°C R/R	NEMA F 105°C R/R	NEMA H 125°C R/R	NEMA F 130°C R/R	NEMA H 150°C R/R
6 Lead, Form Wound Coils and VPI Insulation Systems					
574FSM4380	450	525	560	570	600
741FSM4382①	830	950	975	1000	1040
742FSM4384①	1025	1150	1225	1250	1275
742FSM4386①	1025	1150	1250	1250	1275
742FSM4388①	1160	1360	1475	1475	1500
743FSM4390①	1275	1450	1475	1525	1550
743FSM4392①	1325	1575	1725	1725	1725
744FSM4394①	1575	1875	2000	2025	2050
744FSM4395①	1850	2150	2250	2275	2300
764FSM4397①	2100	2300	2375	2450	2550

MAGNAPOWER® Standard Models

NEMA®* Class F Insulation

All 1000 frame generators have 4 bus bars, with the capability of differential protection.

Base Model	kW Rating @ Designated NEMA Rise				
	Continuous			Standby	
	NEMA B 80°C R/R	NEMA F 105°C R/R	NEMA H 125°C R/R	NEMA F 130°C R/R	NEMA H 150°C R/R
6 Lead, 4 Bus Bars, Form Wound Coils and VPI Insulation Systems					
1020FDH1200①	1850	2100	N/A	2300	N/A
1020FDH1202①	1900	2210	N/A	2390	N/A
1020FDH1204①	2120	2440	N/A	2660	N/A
1030FDH1206①	2400	2800	N/A	3000	N/A
1030FDH1208①	2560	3000	N/A	3300	N/A
Consult factory for extended ratings.					

Medium voltage sensing potential transformers (P/Ts) are not included. For three-phase sensing, a three-phase PT is required. Price adder may apply.

① All 740, 760 and 1000 frame generators on this page have 100 ohm platinum winding RTDs as standard equipment.

[General notes on page 42](#) may apply to this page.
[See available modifications](#) on pages 38.

*NEMA is a trademark or trade name of National Electrical Manufacturers Association and is not owned by or under the control of Marathon Electric LLC.

60 Hertz

4-Pole Three Phase Medium Voltage Generators

**6600Y/3811 Volts
or 3811 Volts Delta**

**1800 RPM
40°C Ambient
0.8 Power Factor Lagging
DVR®2400 AVR w/ PMG Excitation**

MAGNAMAX® Standard Models

NEMA®* Class H Insulation

NOTE: 570, 740 & 760 Frame units MUST employ solidly grounded neutral.

Base Model	kW Rating @ Designated NEMA Rise				
	Continuous			Standby	
	NEMA B 80°C R/R	NEMA F 105°C R/R	NEMA H 125°C R/R	NEMA F 130°C R/R	NEMA H 150°C R/R
6 Lead, Form Wound Coils and VPI Insulation Systems					
574FSM4380	465	550	590	600	625
741FSM4382①	875	1000	1040	1050	1080
742FSM4384①	1000	1100	1200	1200	1250
742FSM4386①	1025	1200	1290	1300	1350
742FSM4388①	1100	1300	1400	1400	1450
743FSM4390①	1290	1460	1550	1600	1600
743FSM4392①	1370	1625	1800	1800	1800
744FSM4394①	1500	1850	2000	2000	2000
744FSM4395①	1800	2150	2320	2320	2320
764FSM4397①	2000	2250	2400	2500	2600

MAGNAPOWER® Standard Models

NEMA®* Class F Insulation

All 1000 frame generators have 4 bus bars, with the capability of differential protection.

Base Model	kW Rating @ Designated NEMA Rise				
	Continuous			Standby	
	NEMA B 80°C R/R	NEMA F 105°C R/R	NEMA H 125°C R/R	NEMA F 130°C R/R	NEMA H 150°C R/R
6 Lead, 4 Bus Bars, Form Wound Coils and VPI Insulation Systems					
1020FDH1200①	1750	2050	N/A	2250	N/A
1020FDH1202①	1800	2170	N/A	2360	N/A
1020FDH1204①	2030	2340	N/A	2540	N/A
1030FDH1206①	2350	2800	N/A	3000	N/A
1030FDH1208①	2500	3000	N/A	3300	N/A
Consult factory for extended ratings.					

Medium voltage sensing potential transformers (P/Ts) are not included. For three-phase sensing, a three-phase PT is required. Price adder may apply.

① All 740, 760 and 1000 frame generators on this page have 100 ohm platinum winding RTDs as standard equipment.

[General notes on page 42](#) may apply to this page.
[See available modifications](#) on pages 38.

60 Hertz

4-Pole Three Phase Medium Voltage Generators

1800 RPM
40°C Ambient
0.8 Power Factor Lagging
DVR®2400 AVR w/PMG Excitation

MAGNAMAX® Standard Models

6900Y/3984 Volts or 3984 Volts Delta

NEMA®* Class H Insulation

NOTE: 570, 740 & 760 Frame units MUST employ solidly grounded neutral.

Base Model	kW Rating @ Designated NEMA Rise				
	Continuous			Standby	
	NEMA B 80°C R/R	NEMA F 105°C R/R	NEMA H 125°C R/R	NEMA F 130°C R/R	NEMA H 150°C R/R
6 Lead, Form Wound Coils and VPI Insulation Systems					
574FSM4380	475	575	600	615	625
741FSM4382①	840	975	1025	1050	1060
742FSM4384①	950	1075	1150	1175	1200
742FSM4386①	975	1150	1225	1250	1250
742FSM4388①	975	1160	1250	1250	1300
743FSM4390①	1265	1450	1525	1575	1575
743FSM4392①	1350	1600	1750	1750	1750
744FSM4394①	1475	1825	1975	2000	2000
744FSM4395①	1725	2075	2225	2250	2250
764FSM4397①	1975	2225	2350	2400	2400

MAGNAPOWER® Standard Models

NEMA®* Class F Insulation

All 1000 frame generators have 4 bus bars, with the capability of differential protection.

Base Model	kW Rating @ Designated NEMA Rise				
	Continuous			Standby	
	NEMA B 80°C R/R	NEMA F 105°C R/R	NEMA H 125°C R/R	NEMA F 130°C R/R	NEMA H 150°C R/R
6 Lead, 4 Bus Bars, Form Wound Coils and VPI Insulation Systems					
1020FDH1200①	1700	2000	N/A	2200	N/A
1020FDH1202①	1750	2090	N/A	2270	N/A
1020FDH1204①	2000	2310	N/A	2520	N/A
1030FDH1206①	2375	2800	N/A	3000	N/A
1030FDH1208①	2530	3000	N/A	3300	N/A

Consult factory for extended ratings.

Medium voltage sensing potential transformers (P/Ts) are not included. For three-phase sensing, a three-phase PT is required. Price adder may apply.

① All 740, 760 and 1000 frame generators on this page have 100 ohm platinum winding RTDs as standard equipment.

[General notes on page 42](#) may apply to this page.

[See available modifications](#) on pages 38.

*NEMA is a trademark or trade name of National Electrical Manufacturers Association and is not owned by or under the control of Marathon Electric LLC.

60 Hertz

4-Pole Three Phase High Voltage Generators

1800 RPM
NEMA®* Class F Insulation
40°C Ambient
0.8 Power Factor Lagging
DVR®2400 AVR w/PMG Excitation
6 Leads

MAGNAPOWER® Standard Models

12470Y/7200 Volts or 7200 Volts Delta

Base Model	kW Rating @ Designated NEMA Rise		
	Continuous		Standby
	NEMA B 80°C R/R	NEMA F 105°C R/R	NEMA F 130°C R/R
861FSH86172	900	1000	1050
862FSH86174	1200	1340	1410
862FSH86176	1280	1420	1500
863FSH86178	1570	1740	1830
863FSH86180	1750	1940	2040
863FSH86182	1800	2000	2100
1020FDH1240	1575	1825	1950
1020FDH1242	1770	2010	2160
1020FDH1244	1770	2000	2160
1020FDH1246	1850	2120	2290
1020FDH1248	2000	2250	2500
1030FDH1250	2170	2500	2700
1030FDH1252	2160	2500	2700
1030FDH1254	2330	2750	3000

Consult factory for extended ratings.

MAGNAPOWER® Standard Models

13200Y/7621 Volts or 7621 Volts Delta

Base Model	kW Rating @ Designated NEMA Rise		
	Continuous		Standby
	NEMA B 80°C R/R	NEMA F 105°C R/R	NEMA F 130°C R/R
861FSH86172	950	1050	1120
862FSH86174	1250	1400	1480
862FSH86176	1315	1460	1530
863FSH86178	1620	1800	1900
863FSH86180	1800	2000	2100
863FSH86182	1850	2050	2160
1020FDH1240	1500	1750	1875
1020FDH1242	1750	2000	2180
1020FDH1244	1800	2010	2250
1020FDH1246	1800	2170	2360
1020FDH1248	2000	2250	2500
1030FDH1250	2150	2500	2700
1030FDH1252	2200	2550	2800
1030FDH1254	2350	2800	3070

Consult factory for extended ratings.

MAGNAPOWER® Standard Models

13800Y/7967 Volts or 7967 Volts Delta

Base Model	kW Rating @ Designated NEMA Rise		
	Continuous		Standby
	NEMA B 80°C R/R	NEMA F 105°C R/R	NEMA F 130°C R/R
861FSH86172	950	1050	1120
862FSH86174	1250	1400	1480
862FSH86176	1350	1500	1575
863FSH86178	1620	1800	1900
863FSH86180	1800	2000	2100
863FSH86182	1900	2100	2200
1020FDH1240	1425	1700	1850
1020FDH1242	1530	1840	2000
1020FDH1244	1750	2000	2180
1020FDH1246	1750	2090	2270
1020FDH1248	1780	2130	2330
1030FDH1250	1970	2350	2570
1030FDH1252	2100	2500	2700
1030FDH1254	2440	2800	3250

Consult factory for extended ratings.

[General notes on page 42](#) may apply to this page.

[See available modifications](#) on pages 38.

- High voltage sensing potential transformers (P/Ts) are not included. For three-phase sensing, a three-phase PT is required.
- All 860 and 1000 frame generators on this page have 100 ohm platinum winding RTDs as standard equipment.
- All high voltage generators incorporate form wound coils and VPI insulation systems.
- All 860 and 1000 frame generators have 4 bus bars, with the capability of differential protection.
- Consult factory for altitude above 3300 feet.

60 Hertz 4-Pole Three Phase Generators

1800 RPM
40°C Ambient
0.8 Power Factor Lagging
DVR®2400 AVR w/PMG Excitation

DATAMAX™

- Low Reactance Designs (Contact factory for other custom reactance value designs)
- Other voltage designs available (Contact factory for details)

All 860 and 1000 frame frame generators have 4 bus bars, with the capability of differential protection.

480Y/277 Volts

Base Model	Winding	80°C		105°C		125°C		130°C		150°C	
		kW	X"d*	kW	X"d*	kW	X"d*	kW	X"d*	kW	X"d*
4 Bars											
743RSL1352	Random	1310	0.084	1600	0.102	1700	0.109	1750	0.112	1750	0.112
744RSL1354	Random	1500	0.060	1850	0.074	1960	0.078	2000	0.080	2000	0.080
744RSL1356	Random	1700	0.081	2010	0.095	2160	0.103	2210	0.105	2260	0.107
764RSL1364	Random	2000	0.070	2250	0.079	2400	0.084	2500	0.088	2650	0.093
6 Leads											
862RSL13006	Random	2300	0.089	2685	0.104	2880	0.112	2880	0.112	3110	0.121
1020RDL1309	Random	2550	0.086	3050	0.103	3250	0.110	3250	0.110	3400	0.115
1020RDL1311	Random	2800	0.106	3250	0.123	3400	0.129	3500	0.133	3600	0.137
863FSL13056	Form	2400	0.094	2730	0.106	3000	0.117	3000	0.117	3100	0.121
1020FDL1300	Form	1880	0.113	2190	0.131	2290	0.137	2340	0.140	2340	0.140
1020FDL1302	Form	2000	0.102	2250	0.115	2500	0.128	2500	0.128	2500	0.128
1020FDL1306	Form	2250	0.096	2710	0.116	2800	0.120	2800	0.120	2800	0.120
1020FDL1308	Form	2340	0.100	2800	0.120	2900	0.124	3000	0.129	3000	0.129
1030FDL1310	Form	2530	0.085	3080	0.104	3260	0.110	3350	0.113	3350	0.113

All 860 and 1000 frame frame generators have 4 bus bars, with the capability of differential protection.

13200Y/7621 Volts

Base Model	80°C		105°C		130°C	
	kW	X"d*	kW	X"d*	kW	X"d*
Form Wound, 6 Leads						
861FSH14152	1100	0.116	1260	0.132	1360	0.143
862FSH14154	1300	0.116	1500	0.133	1620	0.144
862FSH14156	1500	0.104	1750	0.121	1860	0.129
863FSH14158	1680	0.092	2000	0.110	2100	0.115
863FSH14160	1900	0.106	2150	0.120	2350	0.131
1020FDH1440	1500	0.090	1750	0.106	1875	0.113
1020FDH1442	1750	0.105	2000	0.120	2180	0.131
1020FDH1444	1800	0.108	2010	0.121	2250	0.135
1020FDH1446	1800	0.096	2170	0.116	2360	0.126
1020FDH1448	2000	0.101	2250	0.113	2500	0.126
1030FDH1452	2200	0.090	2550	0.105	2800	0.115
1030FDH1454	2350	0.082	2800	0.098	3070	0.107
Consult factory for extended ratings.						

- High voltage sensing potential transformers (P/Ts) are not included. For three-phase sensing, a three-phase PT is required.
- All 860 and 1000 frame generators on this page have 100 ohm platinum winding RTDs as standard equipment.
- All high voltage generators incorporate form wound coils and VPI insulation systems.
- Consult factory for altitude above 3300 fasl.

[General notes on page 42](#) may apply to this page.
[See available modifications](#) on pages 38.

60
Hertz

**4-Pole
Three Phase
Generators**

**1800 RPM
NEMA®* Class H Insulation
40°C Ambient
Shunt (Non-PMG) Excitation
SE350E AVR**

MAGNASELECT®

- The MAGNASELECT® Rental Line generators feature modular design rotary cam switches with solid metal shafts for durable, trouble free service.
- Premounted Voltage Change Switch saves assembly time and money.
- Silver plated contacts and the high tension springs inside the switch guarantee solid connections under rough conditions.
- Generator output terminals are clearly labeled and mounted on the switch for ease of connection to your distribution system. All switches are UL, CE and UL – Canada rated.
- Bolt-on PMG option available
- Maximum amperage determined using a parallel low WYE connection operation at 208V, 3Ph.
- Regulator adjustment required for 208V operation.

**Products are application specific
and require an application
review for proper sizing.**

Consult factory for assistance.



[General notes on page 42](#) may apply to this page.

marathon®

*NEMA is a trademark or trade name of National Electrical Manufacturers Association and is not owned by or under the control of Marathon Electric LLC.



1800 RPM
 NEMA® Class H Insulation
 0.8 Power Factor Lagging
 Dripcover as Required by Marine Agency
 DVR®2400 AVR w/PMG Excitation

MARINE AGENCY CERTIFIED GENERATORS

- Marine Agency certification available (ABS® / Lloyd's Register® / DNV-GL®) for generators up to 2100kW
- NEMA Class H Non-hygroscopic Insulation Systems
- Space Heaters standard on all frame sizes
- All generators include PMG excitation support
- For certification by other Marine Agencies, contact factory for availability and pricing

MARINER®

Base model	NEMA Class F			NEMA Class H		
	kW Ratings @ 95°C R/R over 50°C Ambient			kW Ratings @ 110°C R/R over 45°C Ambient		
	208Y - 240D	450Y	480Y	208Y - 240D	450Y	480Y
12 Lead Reconnectable with Link board Standard						
363PSL3127	100	105	110	110	115	120
431PSL6252	133	135	135	140	143	142
431PSL6254	156	160	160	165	168	170
431PSL6256	183	190	186	191	200	200
431PSL6258	195	198	200	203	210	211
432PSL6260	235	235	235	260	260	260
432PSL6262	245	255	260	260	270	275
433PSL6266	325	325	321	343	346	342
433PSL6270	345	355	352	362	375	375
12 Lead Reconnectable with Bus Bars Standard						
572RSL6325	400	430	430	435	462	450
572RSL6327	415	440	475	445	470	500
572RSL6329	470	505	505	510	547	535
572RSL6331	470	500	515	525	557	575
573RSL6333	610	645	645	650	690	680
573RSL6335	625	652	670	680	725	710
574RSL6337	655	690	700	725	770	800

MAGNAMAX®

Base model	Leads	NEMA Class F			NEMA Class H		
		kW Ratings @ 95°C R/R over 50°C Ambient			kW Ratings @ 110°C R/R over 45°C Ambient		
		208Y - 240D	450Y	480Y	208Y - 240D	450Y	480Y
574RSL4038	4	N/A	720	750	N/A	825	860
575RSL4044	4 Bars		825	870		937	975
740RSL4046	4 Bars		925	970		1080	1120
742RSL4048	4 Bars		1010	1040		1165	1200
742RSL4050	4 Bars		1175	1220		1365	1430
743RSL4052	4 Bars		1425	1425		1660	1600
744RSL4054	4 Bars		1475	1650		1775	1850
744RSL4056	4 Bars		1790	1800		1890	2010
744RSL4057	4 Bars		1880	1880		2020	2100

- ABS witness testing may not be required for units rated below 100 kW.
- Required information at time of order placement: Vessel Name/Hull Number, shipyard, nameplate ratings, and mounting arrangements.
- Winding RTD's are required on Mobil Offshore Drilling Units (MODU) for units rated 400 kW (500 kVA) and above.
- Winding RTD's are required on all units rated 1000 Volts and above.

[General notes on page 42](#) may apply to this page.
[See available modifications](#) on pages 38.

* The following trademarks are not owned by or under the control of Marathon Electric LLC : ABS is a trademark or tradename of American Bureau of Shipping; Lloyd's Register is a tradename of Lloyd's Register Group Limited; NEMA is a trademark or trade name of National Electrical Manufacturers Association.

MARINE AGENCY CLASSIFICATION REQUIREMENTS FOR CERTIFICATION OF SHIPBOARD GENERATORS

Subject	American Bureau Of Shipping (ABS®*)	Lloyd's Register Of Shipping®*	DNV®*
Minimum Rating Requiring Certification	100 kW	100 kW	100 kW
Ambient Temperature	45° C	45° C	45° C
Temperature Rise	110° C	110° C	110° C
Embedded ③ Temperature Detectors	Required for all units 1 kV and over	Required for propulsion systems only	Required for all units
Space Heaters	Required	Not Specified ①	Required
Sustain Short Circuit Current in Percent (%) Rated F.L. Current	300% for 2 Sec.	300% for 2 Sec.	300% for 2 Sec.
Drip Cover or Minimum Enclosure Required	IP22	IP23	IP23
Fixed Termination of Load Leads ②	Not Specified	Required	Required
Shaft Material Test ③	Propulsion Only	Required	Required

Notes: ① Not required by Agency Rules, but strongly advised.

② Generator load leads must be terminated on a fixed terminal such as a bus bar, link board or insulated stand-off.

③ Requires generator to be a build-up

For generators requiring certification by agencies other than those listed in the above table, please consult factory.

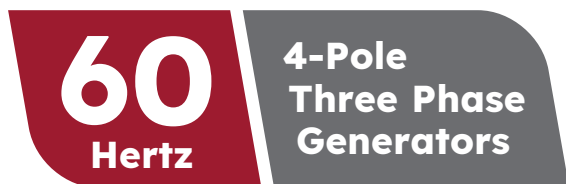

Designed for Marine Diesel Electric Propulsion and Ship Service applications.

MARINER®
DEP/SS

FEATURES AND BENEFITS:

- 450 kW - 2500 kW w/engine specific power nodes
- Supports SCR and IGBT propulsion systems
- Fully taped, form coil, 100% VPI, 4kV, Class H, non-hygroscopic insulation system
- Exciter assembly over dimensioned for durability
- Hardened steel surge ring with coil spacers
- Rotor design lowers rotor temperatures
- Bolt-in, replaceable bearing well
- Subtransient reactance of 12% - 14%
- Enclosures: IP23 + solas, and IP54 TEWAC
- Design: IMB20 / IM 1101 raised foot
- Shaft end: cylindrical shaft suitable for mounting customers coupling
- Three differential CT's mounted on Generator Neutral, 5 amp secondary, C100 class
- Oversized terminal box
- Space heater single phase, 120 or 240V
- Marathon® DVR®2400 AVR, 3 phase sensing with Mil RFI Suppression (supplied loose)
- Manual Voltage Control (supplied loose)
- Cross Current CT (supplied loose)
- Stator RTD's, 2 per phase, 100 ohm platinum
- Bearing RTD's, 1 per bearing, 100 ohm platinum
- PMG - 300% short circuit fault clearing
- Anti-friction bearings on DE / NDE, Re-greasable, L10 life of 40,000 hrs
- Marine certification for ABS, DNV, Lloyds

marathon®

*The following trademarks are not owned by or under the control of Marathon Electric LLC : ABS is a trademark or tradename of American Bureau of Shipping; Lloyd's Register is a tradename of Lloyd's Register Group Limited; Bureau Veritas is a trademark or trade name of Bureau Veritas .

RATINGS

60
Hertz

4-Pole Generators

HAZARDOUS DUTY GENERATORS

Products are application specific and require an application review for proper sizing. Consult factory for assistance.

MAGNAPLUS[®] Models

Shunt (Non-PMG) Excitation
SE350E Voltage regulator shipped loose

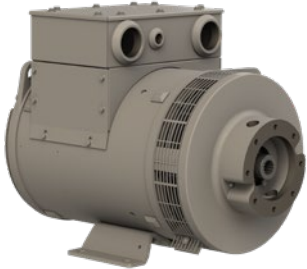

Shown with Optional Hydraulic Adaption

STANDARD FEATURES:

- **Dual Certification**
 - ATEX[®]** Zone 2
 - CSA[®]** Class I, Div 2, Groups A, B, C, & D, Temp Code T3 (200°C)
- Two-Bearing and Single-Bearing Designs
- Marine tested HARSH DUTY windings for use in harsh industrial or environmental applications

OPTIONAL FEATURES:

- Integral Hydraulic Adaption
 - Limited to $\leq 34\text{kW}$ due to mechanical limitations
 - SAE B or SAE C Mounting Flange. 0.88-13T or 1.25-14T internal splined shaft
- Contact factory for Pricing and Availability of Optional Certification
 - IECEx[®]** Zone 2, Temperature Code T3 (200°C), nA nC
- Space heaters are not available

Available in

- Dedicated Single Phase, 4 Leads, 120 Volt or 240/120 Volt
- Three Phase, 12 Leads, 0.8 Power Factor
- 12 lead generators can be reconnected for single phase service.

MAGNAMAX[®] Models

DVR[®]2400 AVR w/ PMG Excitation

STANDARD FEATURES:

- 80°C Maximum Rise by Resistance at 40°C Ambient
- Two Bearing Close-Coupled Adapter
- 100 Ohm Platinum Winding and Bearing RTDs
- Current Transformers for Metering (3) and Paralleling (1)

Dual Certification:

- ATEX[®] Zone 2, Temperature Code T3, nA nC
- CSA[®] Class 1 Group A, B, C, D, Division 2/Zone 2, Group IIA, IIB, IIC Temperature Code T3

OPTIONS:

- Voltages: 120 thru 1000V
- IP23 Single Bearing - or - IP23 or IP44 Double Bearing
- Random or Form Wound available

Optional Certification:

- Marine (ex. ABS[®]*, DNV-GL, Lloyds[®]*)
- IECEx[®] Zone 2, Temperature Code T3, nA nC

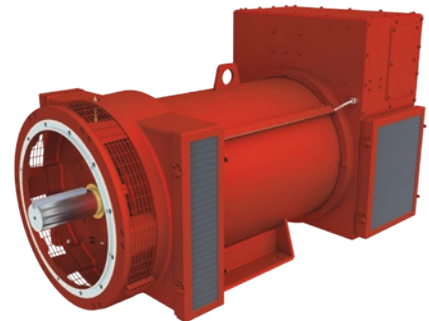

*The following trademarks are not owned by or under the control of Marathon Electric LLC : ABS is a tradename of American Bureau of Shipping; ATEX is a tradename of European Unions; CSA is a tradename of CSA Group; Lloyd's is a tradename of Lloyd's Register Group Limited; IECEx is a tradename of International Electrotechnical Commission.

60
Hertz

**4-Pole
Generators**

1800 RPM
NEMA®* Class H Insulation
40°C Ambient
0.8 Power Factor

IRRIGATOR DUTY™

The Marathon Harsh Duty Generator is an industry-leading generator with a reputation for its robust protection against the toughest elements. Born from DNA of the time tested, rugged componentry in our Harsh Duty Generator, the Irrigator Duty™ includes even more water ingress protection, greatly enhancing its capacity to maintain reliable power through extremely wet or dust-laden environments.

STANDARD FEATURES:

- PM500 AVR voltage regulator (shunt excited)
- Available in one and two-bearing designs

Base model 12 Leads 240Y or 480Y 3Ø	3 Phase Continuous NEMA B 80°C R/R
361PSL1057	20
361PSL1058	25
361PSL1059	30
361PSL1060	40

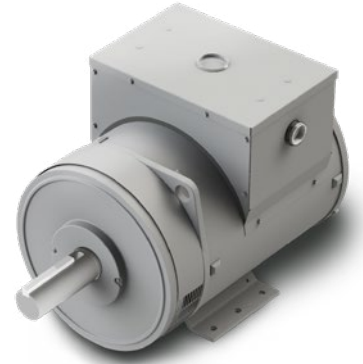

LIMA® MAC IRRIGATOR **Inherently Voltage Regulated**

Its heavy-duty insulation system, louvered air intake and design simplicity stand up to even the most dust and moisture-laden applications.

The LIMA MAC generator also comes with a two year in-service warranty.

STANDARD FEATURES:

- Specifically designed for starting three-phase AC electric motors.
- Provide 1 hp/kW, Code G induction motor starting capability with 35% voltage dip (80°C rise rating).
- Self-excited and inherently-regulated, providing 4% voltage regulation without external voltage regulator or transformers.
- Inherently provide 500% 3 phase short circuit support and volts/hertz operation.

Base model 10 Leads 240Y or 480Y 3Ø	3 Phase Continuous NEMA B 80°C R/R
260MSL1054	10
260MSL1055	12
260MSL1056	15

1800 RPM
NEMA®* Class F Insulation
40°C Ambient
0.8 Power Factor Lagging



60 Hertz 6-Pole Three Phase Generators

1200 RPM
 NEMA®* Class H Insulation
 40°C Ambient
 0.8 Power Factor Lagging
 DVR®2400 AVR w/PMG Excitation

MAGNAMAX®

240Y or 480Y Volts
 480Y Volts

Base model	Continuous			Standby	
	NEMA B 80°C R/R	NEMA F 105°C R/R	NEMA H 125°C R/R	NEMA F 130°C R/R	NEMA H 150°C R/R
	kW	kW	kW	kW	kW
12 Leads, 240Y or 480Y Volts					
572RSL0120	160	180	200	200	210
572RSL0122	200	230	250	250	265
572RSL0124	250	290	315	315	330
573RSL0126	300	348	380	380	400
573RSL0128	400	460	500	500	525
574RSL0130	500	578	630	630	660
6 Leads, 480Y Volts					
742RSL0132	600	690	750	750	790
742RSL0134	730	915	1000	1000	1050
743RSL0136	925	1150	1250	1250	1315
744RSL0138	1100	1375	1500	1500	1575

600Y/346 Volts

Base model	Continuous			Standby	
	NEMA B 80°C R/R	NEMA F 105°C R/R	NEMA H 125°C R/R	NEMA F 130°C R/R	NEMA H 150°C R/R
	kW	kW	kW	kW	kW
12 Leads					
572RSS0140	160	180	200	200	210
572RSS0142	200	230	250	250	265
572RSS0144	255	290	315	315	330
573RSS0146	300	348	380	380	400
573RSS0148	400	460	500	500	525
574RSS0150	490	570	620	620	650
6 Leads					
742RSS0152	600	690	750	750	790
742RSS0154	800	940	1000	1000	1050
743RSS0156	950	1200	1300	1300	1360
744RSS0158	1100	1375	1500	1500	1575

Contact your sales representative for lead time and available agency options.

[General notes on page 42](#) may apply to this page.
[See available modifications](#) on pages 38.

*The following trademarks are not owned by or under the control of Marathon Electric LLC : NEMA is a trademark or trade name of National Electrical Manufacturers Association; UL is a trade name of Underwriters' Laboratories.

60 Hertz 4-Pole Three Phase Generators

DRILL RIG DUTY GENERATORS

1800 RPM
NEMA® Class H Insulation
40°C Ambient
DVR®2400 AVR w/PMG Excitation

MAGNAMAX®

480Y/277 Volts

600Y/346 Volts

Base model	Continuous			Standby
	NEMA B 80°C R/R	NEMA B 80°C R/R	NEMA F 105°C	NEMA F 130°C
	0.7 PF Lagging		0.8 PF Lagging	
	kW	kW	kW	kW
4 Bar				
573FSL4202	400	450	525	575
574FSL4204	500	570	680	750
742FSL4208	700	800	1000	1125
743FSL4210	800	900	1100	1225
743FSL4212	910	1025	1250	1350
744FSL4214	1000	1140	1340	1450
744FSL4216	1200	1375	1675	1825
744FSL4218	1300	1500	1800	1900

Base model	Continuous			Standby
	NEMA B 80°C R/R	NEMA B 80°C R/R	NEMA F 105°C	NEMA F 130°C
	0.7 PF Lagging		0.8 PF Lagging	
	kW	kW	kW	kW
4 Bar				
573FSS4224	400	450	525	575
574FSS4226	520	600	700	750
742FSS4230	700	800	1000	1100
743FSS4232	800	900	1125	1225
743FSS4234	900	1025	1275	1375
744FSS4236	1000	1140	1375	1475
744FSS4238	1200	1375	1525	1625
744FSS4240	1250	1425	1675	1775

Models include VPI insulation (on main stator, exciter stator, exciter rotor, and PMG stator), form wound main stator coil construction, PMG excitation support, IP22 dripcover, and space heaters as standard equipment. All models are specially designed to accept heavy SCR (Thyristor) loading.

60 Hertz 4-Pole Three Phase Generators

CRANE DUTY GENERATORS

Marathon Crane Duty AC generators are designed for Rubber-Tired Gantry Cranes or other mobile/stationary crane applications.

MAGNAMAX®

- Form wound main stator coils with special VPI insulation system (VPI also on exciter stator, exciter rotor, and PMG stator).
- Epoxy overcoat for humid and salt air environments.
- Intake air filters with pressure shut-off switches.
- IP23 weather protected enclosures and space heaters.
- Heavy duty ball bearings with a B-10 life of 40,000 hours.
- Low sub-transient (X"d) reactance and low voltage dip.
- PMG excitation support system and three-phase, true RMS sensing voltage regulator.
- Single or optional two bearing close-coupled engine mounting.

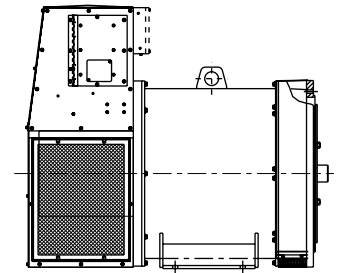

General notes on page 42 may apply to this page.

marathon®

*NEMA is a trademark or trade name of National Electrical Manufacturers Association and is not owned by or under the control of Marathon Electric LLC.

RATINGS

60
Hertz

**4-Pole
Three Phase
Generators**

RAIL DUTY GENERATORS

MECHANICAL DESIGN

- Variable speed / constant speed
- Compact size
- Customized

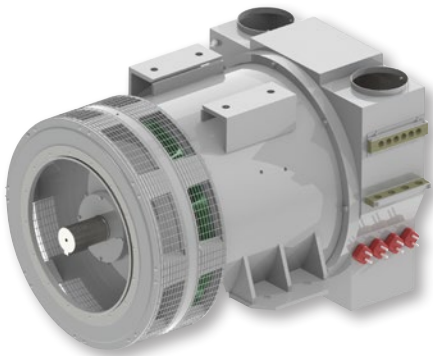
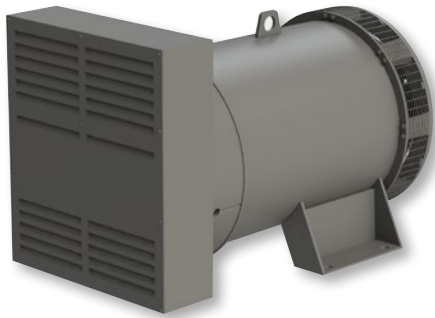

ELECTRICAL DESIGN

- Optimized for the drive system
 - Active / Passive rectification
 - AC / DC Drive systems
 - Constant engine speed 1500 or 1800 RPM
 - Variable engine speed 900 to 2100 RPM
 - Voltage / Current range Optimization
- Rail duty Optimized insulation systems

Head end power (Constant speed), **60 Hz, 1800 RPM, 240/480 V** 0.8 Power Factor Lagging

Frame	kW @ 105°C R/R
431-433	145-380
571-575	495-975
741-744	1030-1800

Propulsion power, **60 Hz, 1800 RPM, 240/480 V** 0.8 Power Factor Lagging

Frame	Max kW @ 105°C R/R
571-575	up to 975
741-744	up to 1800
1020-1030	up to 3000

Propulsion power, **60 Hz, 1800 RPM, 600 V** 0.8 Power Factor Lagging

Frame	Max kW @ 105°C R/R
571-575	up to 900
741-744	up to 1850
1020-1030	up to 2800

**Manufacturing Rail Generators
for over 50 Years**

marathon®

60 Hertz 4-Pole Three Phase Generators

1800 RPM
NEMA®* Class H Insulation
40°C Ambient



STANDARD FEATURES:

- 15, 20, 25 kW
- Voltage regulator: 0.25% regulation; volts per hertz operation, overexcitation shutdown, stability adjust and built in voltage adjustment
- Standard PM500 automatic voltage regulator (shunt excited) for improved motor starting performance
- Added ingress protection
- Winding treated with multiple dip and bake cycles of 100% solids varnish
- Reinforced main stator windings
- Taped and encapsulated exciter stator
- Anti-tracking coated exciter stator



Model Number	kW @ 105°C R/R	Ph	PF
4 Lead Non-Reconnectable			
282PDL28189	15	1	1.0
282PDL28190	20	1	1.0
283PDL28191	25	1	1.0
12 Lead Reconnectable			
283PDL28192	20	3	0.8
283PDL28193	25	3	0.8

50 Hertz 60 Hertz Single Phase Capacitor Designs Generators

LIGHT TOWER APPLICATIONS

NEMA Class F Insulation
40°C Ambient
1.0 Power Factor

Pancake

Base model	rpm	Voltage	kW @80°C R/R	kW @105°C R/R
4 Leads				
201CSA5411	1800	240/120 or 120	5.4	6
201CSA5420	1800	240/120 or 120	7.2	8
201CSA5422	1500	220/110 or 110	5.4	6

CSA models are SAE 5
[General notes on page 42](#) may apply to this page.



**Maximum kW Output
at 40°C ambient
and 130°C R/R for
UL®* 2200 Applications**

**1800 RPM
NEMA®* Class H Insulation
Shunt (Non-PMG) Excitation
SE350E AVR**

MAGNAPLUS® Standard Models

Base model	60 Hz, Three Phase							60 Hz, 1 Phase	
	0.8 PF Lagging							0.8 PF	1.0 PF
	High Wye Connection					Delta	Low Wye	ZigZag	
	480 V	460 V	440 V	416 V	380 V	240 V	208 V	240 V	240 V
12 Lead Reconnectable with Link Board as Standard									
282PSL1704	16.5	16.5	16.2	16	14.5	16	16	10.5	14
282PSL1705	21	21	21	21	19	21	21	13.5	17.5
283PSL1706	27	26	26	25	23	25	25	16	21
283PSL1707	33	32	31	30	27	30	30	18	25
284PSL1708	35	35	35	35	32	35	35	23	30
284PSL1742	40	40	40	40	37	40	40	25	32
285PSL1700	45	45	45	45	41	45	45	28	37
286PSL1701	58	58	56	55	50	55	55	32	42
361PSL1600	48	46	45	42	38	42	42	30	39
361PSL1601	60	60	58	55	50	55	55	35	45
361PSL1602	70	67	68	65	60	65	65	42	55
362PSL1604	90	86	84	80	72	80	80	51	66
362PSL1606	105	105	102	100	90	100	100	60	79
363PSL1607	135	135	130	125	115	125	125	73	97
364PSL1608	155	155	155	155	140	155	155	85	110
364PSL1609	180	180	180	175	160	175	175	95	125
431PSL6202	155	155	153	151	140	151	151	96	121
431PSL6204	181	182	180	176	167	176	176	107	135
431PSL6206	215	220	220	210	191	210	210	132	166
431PSL6208	230	230	225	225	207	225	225	132	166
432PSL6210	280	282	283	280	265	280	280	161	201
432PSL6212	300	300	290	280	265	280	280	161	201
433PSL6216	380	380	280	375	357	375	375	193	241
433PSL6220	415	410	410	400	367	400	400	193	241

[General notes on page 42](#) may apply to this page.
[See available modifications](#) on pages 38–41..

*The following trademarks are not owned by or under the control of Marathon Electric LLC: NEMA is a trademark or trade name of National Electrical Manufacturers Association; UL is a trade name of Underwriters' Laboratories.



**Maximum kW Output
at 40°C ambient
and 130°C R/R for
UL®* 2200 Applications**

**1800 RPM
NEMA®* Class H Insulation
Includes PMG Excitation**

MAGNAMAX® Standard Models

PM500

Base model	60 Hz, Three Phase						60 Hz, 1 Phase		
	0.8 PF Lagging								
	High Wye Connection					Delta	Low Wye	ZigZag	
	480 V	440 V	416 V	400 V	380 V	240 V	208 V	240 V	240 V
Random Wound Coil Designs, 12 Lead Reconnectable with Bus Bars Standard									
572RSL6425 ①	475	465	440	422	400	440	440	209	261
572RSL6427 ①	515	500	475	443	405	475	475	227	283
572RSL6429 ①	560	560	525	500	470	525	525	246	308
572RSL6431 ①	600	590	565	529	485	565	565	264	330
573RSL6433 ①	700	730	700	652	595	700	700	308	385
573RSL6435 ①	750	765	725	680	625	725	725	330	413
574RSL6437 ①	825	820	785	733	670	785	785	363	454

DVR®2400

Random Wound Coil Designs, 4 Bars									
574RSL6438 ①	920	875	835	776	705	N/A	N/A	N/A	N/A
575RSL4044	1060	1010	975	909	830	N/A	N/A	N/A	N/A
741RSL4044	1100	1030	1000	927	840	N/A	N/A	N/A	N/A
740RSL4046	1220	1160	1110	1035	945	N/A	N/A	N/A	N/A
742RSL4048	1300	1240	1180	1112	1030	N/A	N/A	N/A	N/A
742RSL4050	1500	1450	1370	1275	1160	N/A	N/A	N/A	N/A
743RSL4052	1750	1710	1610	1552	1480	N/A	N/A	N/A	N/A
744RSL4054	2000	1920	1840	1727	1590	N/A	N/A	N/A	N/A
744RSL4056	2210	2030	1950	1879	1790	N/A	N/A	N/A	N/A
744RSL4057	2320	2180	2090	2028	1950	N/A	N/A	N/A	N/A
764RSL4063	2500	2300	2170	2070	1970	N/A	N/A	N/A	N/A
Form Wound Coil Designs, 4 Bars									
573FSL4402	575	530	500	480	460	N/A	N/A	N/A	N/A
574FSL4404	750	690	650	630	590	N/A	N/A	N/A	N/A
742FSL4408	1125	1030	980	940	890	N/A	N/A	N/A	N/A
743FSL4410	1225	1120	1060	1020	970	N/A	N/A	N/A	N/A
743FSL4412	1350	1240	1170	1130	1070	N/A	N/A	N/A	N/A
744FSL4060	1500	1460	1440	1368	1280	N/A	N/A	N/A	N/A
744FSL4062	1900	1860	1830	1750	1650	N/A	N/A	N/A	N/A
744FSL4414	2110	2140	2040	1980	1900	N/A	N/A	N/A	N/A

MAGNAPOWER® Standard Models

All 860 & 1000 frame generators have 4 bus bars, with the capability of differential protection.

DVR®2400

Random Wound Coil Designs, 6 Leads									
861RSL86006	2880	N/A	2800	2690	2560	N/A	N/A	N/A	N/A
1020RDL1109	3250	N/A	3100	2950	2800	N/A	N/A	N/A	N/A
1020RDL1111	3500	N/A	3300	3150	3000	N/A	N/A	N/A	N/A
Form Wound Coil Designs, 6 Leads									
1020FDL1100	2340	N/A	2320	2260	2180	N/A	N/A	N/A	N/A
1020FDL1102	2500	N/A	2500	2430	2340	N/A	N/A	N/A	N/A
1020FDL1104	2680	N/A	2660	2590	2500	N/A	N/A	N/A	N/A
1020FDL1106	2800	N/A	2760	2660	2550	N/A	N/A	N/A	N/A
863FSL86056	3000	N/A	2700	2600	2500	N/A	N/A	N/A	N/A
1020FDL1108	3000	N/A	2850	2740	2600	N/A	N/A	N/A	N/A
1030FDL1110	3350	N/A	3250	3125	3000	N/A	N/A	N/A	N/A

① PM500 standard.

General notes on page 42 may apply to this page.

See available modifications on pages 38.



*NEMA is a trademark or trade name of National Electrical Manufacturers Association and is not owned by or under the control of Marathon Electric LLC.

RATINGS

Modification Section: Generators

Modification	Description	280	360	430	570	740
Adapters	GM 7.4/5.7 L	⊙	●	⊙	⊙	⊙
	Two-bearing close-coupled	⊙	⊙	⊙	▲	▲
Air Filters	Reduce catalog ratings 5% if equipped with filters	⊙	⊙	⊙	●	●
Oversized Conduit Box	Consult factory for available options.	●	⊙	⊙	⊙	⊙
Drip Cover	IP22 or IP23, shipped loose for 280 frame, 360 frame SAE #1 no IP22	●	●	●	●	●
Foot Options	Low rise on 360 & 430 frame sizes	⊙	●	●	⊙	⊙
	Non-standard feet	⊙	⊙	⊙	▲	▲
Hazardous Duty	CSA** Certified for Class I, Group A, B, C, D, Div. 2 / Zone 2 Group IIA, IIB, IIC					
	Temperature Code T3. Generator must be selected at 80°C rise.					
	Space Heaters available on 430-740 frame only, Temperature code will be T2B	●	⊙	●	●	●
	Regulator shipped loose for remote mounting					
	Excludes 286 frame					
Non-standard paint finish	Gray primer is standard. Other finish options will incur an upcharge.	●	●	●	●	●
Pilot Shaft	(Use with CAT engines) Pilot Diameters (3.148", 3.935", 4.723", & 5.116")	⊙	⊙	⊙	●	●
PMG Excitation	SE350 or SE350EL - see model list for availability	■	■	■	⊙	⊙
	Permanent Magnet Generator & PM500 Regulator - see model list for availability	●	●	●	■	⊙
	Permanent Magnet Generator & DVR®2400 Regulator- see model list for availability	●	●	●	●	■
	Permanent Magnet Generator & DVR®2500 Regulator - see model list for availability	●	●	●	●	●
Space Heaters 240 / 120V	Watts vary by frame size	● 84W	● 250W	● 250W	● 500W	● 1000W
West Coast Crating	Additional product protection during shipping	●	●	●	⊙	⊙
Custom Nameplate	Custom designed nameplate	●	●	●	●	●
Stator RTD	MagnaMax	⊙	⊙	●	●	●
Bearing RTD	MagnaMax	⊙	⊙	●	●	●
Current Transformer	Paralleling, Metering, or Differential	⊙	⊙	⊙	●	●
Sensing Transformer	15VA up to 4160V, with 240V secondary for DVR (1Ph) Regulators	Discontinued				
Sensing Transformer	3 Phase 15VA/phase up to 7200V, with 120V or 230V secondary for DVR (3Ph) Regulators	⊙	⊙	⊙	●	●
Sensing Transformer	Consult Factory for voltages above 7200 V	▲	▲	▲	▲	▲
4 Bus Bar	572-574Fr (480-600V)	⊙	⊙	⊙	●	⊙
6 Bus Bar	572-574Fr (480-600V)	⊙	⊙	⊙	●	⊙
6 Bus Bar	740-744Fr (480-600V)	⊙	⊙	⊙	⊙	●
4 Bus Bar	573-574Fr (600-6600V)	⊙	⊙	⊙	●	⊙
4 Bus Bar	741-744Fr (600-6600V)	⊙	⊙	⊙	⊙	●
6 Bus Bar	741-744Fr (600-6600V)	⊙	⊙	⊙	⊙	●

■ standard ⊙ not available ▲ consult sales rep for additional information ● Optional; upcharge may apply, depending on model
 * available on Mariner / Harsh Duty

Modification	Description
Adapters	Non-STD SAE XG's
Circuit Breaker	Three Pole (80% rated)
Export Crating	Freight not included. See freight policy. Add up to two weeks to lead time
Hydraulic Drive	SAE B or C mounting flange with 13 tooth (0.88"-13T) or 14 tooth (1.25"-14T) internal splined shaft. 34kW mechanical limit.
Instrument Panel	Meter panel, selector switch and current transformers
Special Insulation	Std on Mariner / Harsh Duty models. Other units: Contact sales.
Special Windings	MagnaMax / MagnaPower
Manual Voltage Control	MVC 300 for DVR (shipped loose)

We understand that OEMs may have special requirements for their alternator needs.

For large / ongoing contracts, we can provide special modifications, including those listed here.

Please note: minimum order quantities apply. Contact sales for details.

*CSA is a trademark of CSA Group and is not owned by or under the control of Marathon Electric LLC.

Modification Section: 280 Frame MagnaPlus® Generators

Includes: standard connection box, gray primer and mylar nameplate

Available Mods: drip covers (IP22 or IP23) - shipped loose, space heater - shipped loose, oversized box, black paint

Adapter Size	Adaption											Regulator			Bolt-On PMG Compatible
	5	5	5	4	4	4	4	3	3	3	2Brg	SE350 SE350EL	PM500	DVR2400	
Coupling Size	6.5	7.5	8	6.5	7.5	8	10	8	10	11.5					
Three phase, 208 Volts - 480 Volts, 12 Lead															
282PSL1704	STD	STD	opt	opt	opt	opt	opt	opt	opt	opt	n/a	STD	n/a	n/a	yes
282PSL1705	opt	STD	opt	opt	STD	opt	STD	opt	opt	opt	n/a	STD	n/a	n/a	yes
283PSL1706	opt	STD	opt	opt	STD	opt	STD	opt	opt	opt	n/a	STD	mod	mod	yes
283PSL1707	opt	opt	opt	opt	STD	opt	STD	opt	opt	STD	n/a	STD	mod	mod	yes
284PSL1708	opt	opt	opt	opt	opt	opt	STD	opt	opt	STD	n/a	STD	mod	mod	yes
284PSL1742	opt	opt	opt	opt	STD	opt	STD	opt	opt	STD	n/a	STD	mod	mod	yes
285PSL1700	opt	opt	opt	opt	opt	opt	STD	opt	opt	opt	n/a	STD	mod	mod	yes
286PSL1701	opt	opt	opt	opt	STD	opt	opt	opt	opt	STD	n/a	STD	mod	mod	yes

Single phase, 120 Volts - 240 Volts, 4 Lead															
282PSL1714	STD	opt	opt	opt	opt	opt	opt	opt	opt	opt	n/a	STD	n/a	n/a	yes
282PSL1715	opt	opt	opt	opt	STD	opt	opt	opt	opt	opt	n/a	STD	n/a	n/a	yes
282PSL1716	opt	opt	opt	opt	STD	opt	opt	opt	opt	opt	n/a	STD	n/a	n/a	yes
283PSL1717	opt	opt	opt	opt	STD	opt	opt	opt	opt	opt	n/a	STD	mod	mod	yes
283PSL1718	opt	opt	opt	opt	STD	opt	opt	opt	opt	opt	n/a	STD	mod	mod	yes
284PSL1750	opt	opt	opt	opt	STD	opt	opt	opt	opt	opt	n/a	STD	mod	mod	yes

Three phase, Dedicated Voltage Designs - 600 Volts, 4 Lead															
282PSL5249	opt	opt	opt	opt	opt	opt	STD	opt	opt	opt	n/a	STD	n/a	n/a	yes
283PSL5250	opt	opt	opt	opt	opt	opt	STD	opt	opt	opt	n/a	STD	mod	mod	yes
283PSL5251	opt	opt	opt	opt	opt	opt	STD	opt	opt	opt	n/a	STD	mod	mod	yes
284PSL5252	opt	opt	opt	opt	opt	opt	STD	opt	opt	opt	n/a	STD	mod	mod	yes
284PSL5253	opt	opt	opt	opt	opt	opt	STD	opt	opt	opt	n/a	STD	mod	mod	yes

Mariner / Harsh Duty															
282PSL28043	opt	opt	opt	opt	STD	opt	opt	opt	opt	opt	STD	STD	mod	mod	yes
283PSL28045	opt	opt	opt	opt	STD	opt	opt	opt	opt	opt	STD	STD	mod	mod	yes
284PSL28047	opt	opt	opt	opt	opt	opt	opt	opt	opt	STD	STD	STD	mod	mod	yes
285PSL28048	opt	opt	opt	opt	opt	opt	opt	opt	opt	STD	n/a	STD	mod	mod	yes

STD = standard model

opt = optional adaption at no charge

mod = upcharge for modification

Note - OS Box required for PM500 and DVR

Modification Section: 360 Frame MagnaPlus® Generators

Includes: standard connection box, gray primer and mylar nameplate

Available Mods: drip cover IP22 (Not available on SAE #1), drip cover IP23, space heater, black paint

Adapter Size	Adaption Regulator												Regulator			Bolt-On PMG Compatible
	4	4	4	3	3	3	2	2	1	1	GM	2Brg	SE350 SE350EL	PM500	DVR2400	
Coupling Size	7.5	8	10	8	10	11.5	10	11.5	11.5	14	mod					
Three phase, 208 Volts - 480 Volts, 12 Lead																
361PSL1600	opt	opt	STD	opt	opt	STD	opt	opt	opt	n/a	mod	n/a	STD	mod	mod	yes
361PSL1601	STD	opt	STD	opt	opt	STD	opt	opt	opt	n/a	mod	n/a	STD	mod	mod	yes
361PSL1602	opt	opt	STD	opt	opt	STD	opt	opt	opt	n/a	mod	n/a	STD	mod	mod	yes
362PSL1604	opt	opt	opt	opt	opt	STD	opt	opt	opt	n/a	mod	n/a	STD	mod	mod	yes
362PSL1606	opt	opt	opt	opt	opt	STD	opt	opt	opt	n/a	mod	n/a	STD	mod	mod	yes
363PSL1607	opt	opt	opt	opt	opt	STD	opt	opt	opt	n/a	mod	n/a	STD	mod	mod	yes
364PSL1608	opt	opt	opt	opt	opt	STD	opt	opt	opt	n/a	mod	n/a	STD	mod	mod	yes
364PSL1609	opt	opt	opt	opt	opt	STD	opt	opt	opt	n/a	mod	n/a	STD	mod	mod	yes

Single phase, 120 Volts - 240 Volts, 4 Lead																
361PSL1613	opt	opt	opt	opt	opt	STD	opt	opt	opt	n/a	mod	n/a	STD	mod	mod	yes
362PSL1615	opt	opt	opt	opt	opt	STD	opt	opt	opt	n/a	mod	n/a	STD	mod	mod	yes
363PSL1617	opt	opt	opt	opt	opt	STD	opt	opt	opt	n/a	mod	n/a	STD	mod	mod	yes

Three phase, Dedicated Voltage Designs - 600 Volts, 4 Lead																
361PSL1633	opt	opt	opt	opt	opt	STD	opt	opt	opt	n/a	mod	n/a	STD	mod	mod	yes
361PSL1634	opt	opt	opt	opt	opt	STD	opt	opt	opt	n/a	mod	n/a	STD	mod	mod	yes
362PSL1635	opt	opt	opt	opt	opt	STD	opt	opt	opt	n/a	mod	n/a	STD	mod	mod	yes
362PSL1636	opt	opt	opt	opt	opt	STD	opt	opt	opt	n/a	mod	n/a	STD	mod	mod	yes
363PSL1658	opt	opt	opt	opt	opt	STD	opt	opt	opt	n/a	mod	n/a	STD	mod	mod	yes

Mariner / Harsh Duty																
361PSL3120	opt	opt	opt	opt	opt	STD	opt	opt	opt	n/a	mod	STD	STD	mod	mod	yes
361PSL3121	STD	opt	opt	opt	opt	STD	opt	opt	opt	n/a	mod	STD	STD	mod	mod	yes
361PSL3122	opt	opt	opt	opt	opt	STD	opt	opt	opt	n/a	mod	STD	STD	mod	mod	yes
362PSL3124	opt	opt	opt	opt	opt	STD	opt	opt	opt	n/a	mod	STD	STD	mod	mod	yes
362PSL3126	opt	opt	opt	opt	opt	STD	opt	opt	opt	n/a	mod	STD	STD	mod	mod	yes
363PSL3127	opt	opt	opt	opt	opt	STD	opt	opt	opt	STD	mod	STD	STD	mod	mod	yes

Marine Agency Certified Generators Models																
363PSL3127	opt	opt	opt	opt	opt	STD	opt	opt	opt	n/a	mod	C/F	n/a	mod	STD	yes

STD = standard model
 opt = optional adaption at no charge
 mod = upcharge for modification

Modification Section: 430 Frame MagnaPlus® Generators

Includes: standard connection box, gray primer and mylar nameplate

Available Mods: drip cover IP22, drip cover IP23, space heater, black paint

Adapter Size	Adaption							Regulator			Bolt-On PMG Compatible
	3	3	2	2	1	1	2brg	SE350 SE350EL	PM500	DVR2400	
Coupling Size	10	11.5	10	11.5	11.5	14	LS				
Three phase, 208 Volts - 480 Volts, 12 Lead											
431PSL6202	opt	STD	opt	opt	opt	STD	n/a	STD	mod	mod	yes
431PSL6204	opt	STD	opt	opt	opt	STD	n/a	STD	mod	mod	yes
431PSL6206	opt	STD	opt	STD	opt	STD	n/a	STD	mod	mod	yes
431PSL6208	opt	opt	opt	STD	opt	opt	n/a	STD	mod	mod	yes
432PSL6210	opt	STD	opt	STD	opt	STD	n/a	STD	mod	mod	yes
432PSL6212	opt	STD	opt	opt	opt	STD	n/a	STD	mod	mod	yes
433PSL6216	opt	opt	opt	STD	opt	STD	n/a	STD	mod	mod	yes
433PSL6220	opt	opt	opt	opt	opt	STD	n/a	STD	mod	mod	yes
Single phase, 120 Volts - 240 Volts, 4 Lead											
431PSL6224	opt	STD	opt	opt	opt	opt	n/a	STD	mod	mod	yes
431PSL6226	opt	STD	opt	opt	opt	opt	n/a	STD	mod	mod	yes
432PSL6228	opt	STD	opt	opt	opt	opt	n/a	STD	mod	mod	yes
Three phase, Dedicated Voltage Designs - 600 Volts, 4 Lead											
431PSL6240	opt	STD	opt	STD	opt	opt	n/a	STD	mod	mod	yes
431PSL6242	opt	opt	opt	STD	opt	opt	n/a	STD	mod	mod	yes
431PSL6243	opt	opt	opt	STD	opt	opt	n/a	STD	mod	mod	yes
432PSL6246	opt	opt	opt	opt	opt	STD	n/a	STD	mod	mod	yes
433PSL6248	opt	opt	opt	opt	opt	STD	n/a	STD	mod	mod	yes
Mariner / Harsh Duty											
431PSL6252	opt	opt	opt	STD	opt	opt	n/a	STD	mod	mod	yes
431PSL6254	opt	STD	opt	STD	opt	opt	STD	STD	mod	mod	yes
431PSL6256	opt	opt	opt	STD	opt	STD	n/a	STD	mod	mod	yes
431PSL6258	opt	opt	opt	STD	opt	opt	STD	STD	mod	mod	yes
432PSL6260	opt	opt	opt	STD	opt	STD	n/a	STD	mod	mod	yes
432PSL6262	opt	opt	opt	STD	opt	opt	STD	STD	mod	mod	yes
433PSL6266	opt	opt	opt	opt	opt	STD	n/a	STD	mod	mod	yes
433PSL6270	opt	opt	opt	opt	opt	STD	STD	STD	mod	mod	yes
Marine Agency Certified Generators Models											
431PSL6252	opt	opt	opt	STD	opt	opt	C/F	n/a	mod	STD	yes
431PSL6254	opt	STD	opt	opt	opt	opt	C/F	n/a	mod	STD	yes
431PSL6256	opt	opt	opt	STD	opt	opt	C/F	n/a	mod	STD	yes
431PSL6258	opt	opt	opt	STD	opt	opt	C/F	n/a	mod	STD	yes
432PSL6260	opt	opt	opt	STD	opt	opt	C/F	n/a	mod	STD	yes
432PSL6262	opt	opt	opt	opt	opt	STD	C/F	n/a	mod	STD	yes
433PSL6266	opt	opt	opt	opt	opt	STD	C/F	n/a	mod	STD	yes
433PSL6270	opt	STD	opt	opt	opt	opt	C/F	n/a	mod	STD	yes

STD = standard model
 opt = optional adaption at no charge
 mod = upcharge for modification
 C/F= Call Factory



General Notes

- A. All base models listed (except 1000 frame MAGNAPOWER® models) are single bearing. Pricing includes flexible drive discs, SAE adapter, standard voltage regulator, and full guarding. Drip covers are Optional. All voltage regulators have underspeed protection, EMI filtering, and are encapsulated for moisture protection.
- B. MAGNAPLUS® and MAGNAMAX® products have Class H insulation. LIMA®MAC products have Class H insulation on the rotor, and Class F insulation on the stator. MAGNAPOWER® products have Class H insulation for 4160V and below, and Class F insulation for above 4160V. Pancake products have Class F insulation. Rating columns headed NEMA®* B, F, and H indicate that generators operated at the specified ratings will not exceed the temperature rise limitation for the specified class of insulation specified in NEMA MG1-32.6. The rating columns do not specify the class of insulation used in the generator's construction.
- C. The frame size for each model is the first 3 or 4 digits of the model number.
- D. All generator ratings listed in this publication are based upon temperature rises measured by the resistance method as defined by MIL-STD-705C and IEEE STD 115, Method 6.4.4. For ratings at rises as measured by embedded temperature detectors, consult factory.
- E. Pancake AVR and MAGNAPLUS® products are shunt-excited (non-PMG) generators. The automatic voltage regulator derives input power from the generator's output leads.
- F. MAGNAMAX® and MAGNAPOWER® generators incorporate a permanent magnet generator (PMG) as the input power source for the voltage regulator.
- G. MAGNAMAX® and MAGNAPOWER® form wound coil generators include VPI insulation on main stator only.

Technical Data

Mounting Arrangement Cross Reference

Adapter Size	Coupling Size	Available in Frame Sizes					
		MagnaPlus 280 - 430	MagnaMax			Pancake	Lima Mac
			570	740	760	330	260
5	6.5	"See pages 38-40 for adaption"				Std.	Std.
5	7.5					Std.	Std.
5	8						*
4	6.5					Std.	Std.
4	7.5					Std.	Std.
4	8						*
4	10						*
3	8						
3	10						
3	11.5						
2	10						
2	11.5						
1	11.5						
1	14			Std.			
1	ACDelco 17.75			Std.			
1/2	ACDelco 17.75			Std.			
1/2	14			Std.			
0	ACDelco 17.75			Std.	Std.		
0	14			Std.			
0	18			Std.	Std.		
00	18			Std.	Std.	Std.	
00	21			Std.	Std.		

STD = Standard adaption available at no additional cost.
 * - Available as loose kit

Dimensions & Weights

in inches and (millimeters)

Standard SAE Dimensions

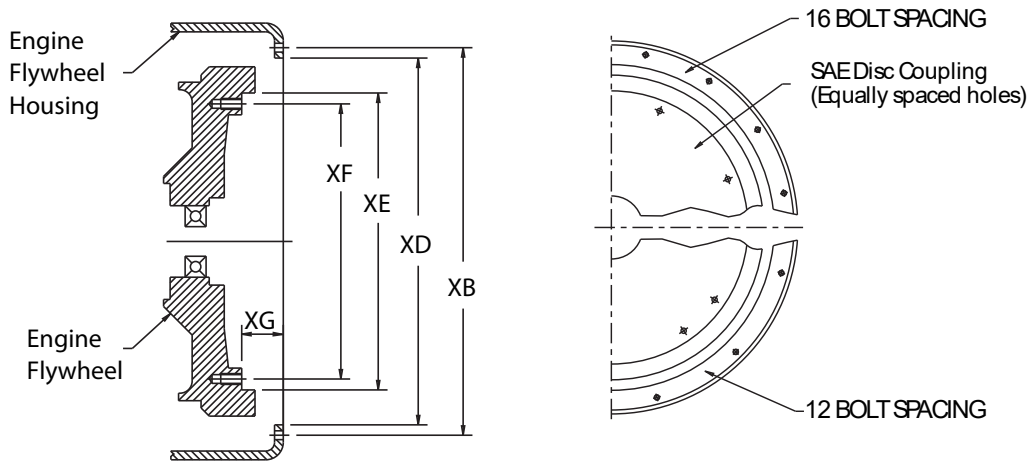

Engine Flywheel Housing Dimensions				
SAE No.	XD	XB	Tapped Holes	
			Qty.	Size
00	31.000 (787)	33.50 (851)	16	1/2-13
0	25.500 (648)	26.75 (679)	16	1/2-13
1/2	23.000 (584)	24.38 (619)	12	1/2-13
1	20.125 (511)	20.88 (530)	12	7/16-14
2	17.625 (448)	18.38 (467)	12	3/8-16
3	16.125 (410)	16.88 (429)	12	3/8-16
4	14.250 (362)	15.00 (381)	12	3/8-16
5	12.375 (314)	13.12 (333)	8	3/8-16
6	10.500 (267)	11.25 (286)	8	3/8-16

Engine Flywheel Dimensions					
Size	XE	XF	XG	Tapped Holes	
				Qty.	Size
SAE 21	26.500 (673)	25.25 (641)	0 (0)	12	5/8-11
SAE 18	22.500 (572)	21.38 (543)	.62 (16)	6	5/8-11
SAE 14	18.375 (467)	17.25 (438)	1.00 (25)	8	1/2-13
SAE 11-1/2	13.875 (352)	13.12 (333)	1.56 (40)	8	3/8-16
SAE 10	12.375 (314)	11.62 (295)	2.12 (54)	8	3/8-16
SAE 8	10.375 (264)	9.62 (244)	2.44 (62)	6	3/8-16
SAE 7-1/2	9.500 (241)	8.75 (222)	1.19 (30)	8	5/16-18
SAE 6-1/2	8.500 (216)	7.88 (200)	1.19 (30)	6	5/16-18

MARINER® HARSH DUTY®

Mariner & Harsh Duty Net Weight in pounds

Base Model	Weight
282PSL28043	295
283PSL28045	366
284PSL28047	436
285PSL28048	480
361PSL3120	518
361PSL3121	569
361PSL3122	620
362PSL3124	706
362PSL3126	796
363PSL3127	943

Base Model	Weight
431PSL6252	1220
431PSL6254	1310
431PSL6256	1415
431PSL6258	1455
432PSL6260	1685
432PSL6262	1760
433PSL6266	2235
433PSL6270	2245

Base Model	Weight
572RSL6325	2730
572RSL6327	2840
572RSL6329	3050
572RSL6331	3110
573RSL6333	3400
573RSL6335	3620
574RSL6337	4080

Dimensions & Weights

in inches and (millimeters)

ALL DIMENSIONS ARE APPROXIMATE: Contact factory for full dimensional data.

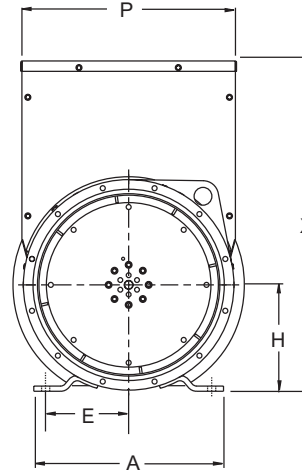
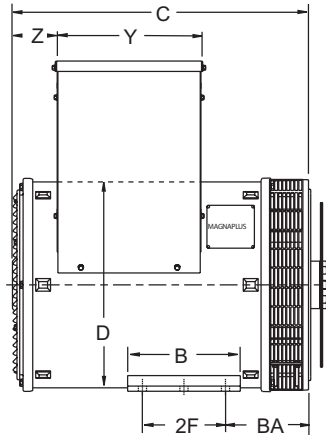

280-430 frame

Frame Size	A	B	BA	C	C with PMG	D	E	2F	H	P	X	Y	Z
282	14.00	7.00	6.56	18.50	23.10	13.64	6.25	5.00	8.00	13.55	18.56	8.93	3.42
	(356)	(178)	(167)	(470)	(587)	(346)	(159)	(127)	(203)	(344)	(471)	(227)	(87)
283	14.00	7.00	6.56	20.50	25.10	13.64	6.25	5.00	8.00	13.55	18.56	8.93	3.42
	(356)	(178)	(167)	(521)	(638)	(346)	(159)	(127)	(203)	(344)	(471)	(227)	(87)
284	14.00	7.00	6.56	22.75	27.40	13.64	6.25	5.00	8.00	13.55	18.56	8.93	3.42
	(356)	(178)	(167)	(578)	(696)	(346)	(159)	(127)	(203)	(344)	(471)	(227)	(87)
285	14.00	7.00	6.56	25.00	29.60	13.64	6.25	5.00	8.00	13.55	18.56	8.93	3.42
	(356)	(178)	(167)	(635)	(752)	(346)	(159)	(127)	(203)	(344)	(471)	(227)	(87)
286	14.00	7.00	11.56	27.00	31.60	13.64	6.25	5.00	8.00	13.55	18.56	8.93	3.42
	(356)	(178)	(294)	(686)	(803)	(346)	(159)	(127)	(203)	(344)	(471)	(227)	(87)
361	16.00	9.50	7.00	24.96	27.56	17.35	7.00	7.00	9.00	18.19	27.85	12.44	3.52
	(406)	(241)	(178)	(634)	(700)	(441)	(178)	(178)	(229)	(462)	(707)	(316)	(89)
362	16.00	9.50	7.00	28.59	31.18	17.35	7.00	7.00	9.00	18.19	27.85	12.44	3.52
	(406)	(241)	(178)	(726)	(792)	(441)	(178)	(178)	(229)	(462)	(707)	(316)	(89)
363	16.00	9.50	10.50	31.72	34.29	17.35	7.00	7.00	9.00	18.19	27.85	12.44	3.52
	(406)	(241)	(267)	(806)	(871)	(441)	(178)	(178)	(229)	(462)	(707)	(316)	(89)
364	16.00	9.50	10.50	34.92	37.28	17.35	7.00	7.00	9.00	18.19	27.85	12.44	3.52
	(406)	(241)	(267)	(887)	(947)	(441)	(178)	(178)	(229)	(462)	(707)	(316)	(89)
431	21.46	15.00	10.00	33.89	38.27	22.64	9.00	11.00	13.00	24.97	36.10	16.00	2.66
	(545)	(381)	(254)	(861)	(972)	(575)	(229)	(279)	(330)	(634)	(917)	(406)	(68)
432	21.46	15.00	10.00	37.39	41.77	22.64	9.00	11.00	13.00	24.97	36.10	16.00	2.66
	(545)	(381)	(254)	(950)	(1061)	(575)	(229)	(279)	(330)	(634)	(917)	(406)	(68)
433	21.46	15.00	10.00	42.39	46.77	22.64	9.00	11.00	13.00	24.97	36.10	16.00	2.66
	(545)	(381)	(254)	(1077)	(1188)	(575)	(229)	(279)	(330)	(634)	(917)	(406)	(68)

Must have minimum clearance of 6 inches for air flow in to the generator. Additional clearance may be required for servicing.

MagnaPlus Net Weight in pounds

Base Model	Weight
282PSL1704	270
282PSL1705	295
282PSL1714	236
282PSL1715	265
282PSL1716	288
282PSL5249	295
283PSL1706	336
283PSL1707	366
283PSL1717	331
283PSL1718	360
283PSL5250	336

Base Model	Weight
283PSL5251	366
284PSL1708	405
284PSL1742	436
284PSL1750	430
284PSL5252	405
284PSL5253	436
285PSL1700	480
286PSL1701	600
361PSL1600	518
361PSL1601	569

Base Model	Weight
361PSL1602	620
361PSL1613	626
361PSL1633	569
361PSL1634	620
362PSL1604	706
362PSL1606	796
362PSL1615	779
362PSL1635	706
362PSL1636	796
363PSL1607	943

Base Model	Weight
363PSL1617	929
363PSL1658	943
364PSL1608	1086
364PSL1609	1096
431PSL6202	1220
431PSL6204	1310
431PSL6206	1415
431PSL6208	1455
431PSL6224	1280
431PSL6226	1600

Base Model	Weight
431PSL6240	1220
431PSL6242	1415
431PSL6243	1455
432PSL6210	1685
432PSL6212	1760
432PSL6228	1720
432PSL6246	1760
433PSL6216	2235
433PSL6220	2245
433PSL6248	2245

Dimensions & Weights

in inches and (millimeters)

ALL DIMENSIONS ARE APPROXIMATE: Contact factory for full dimensional data

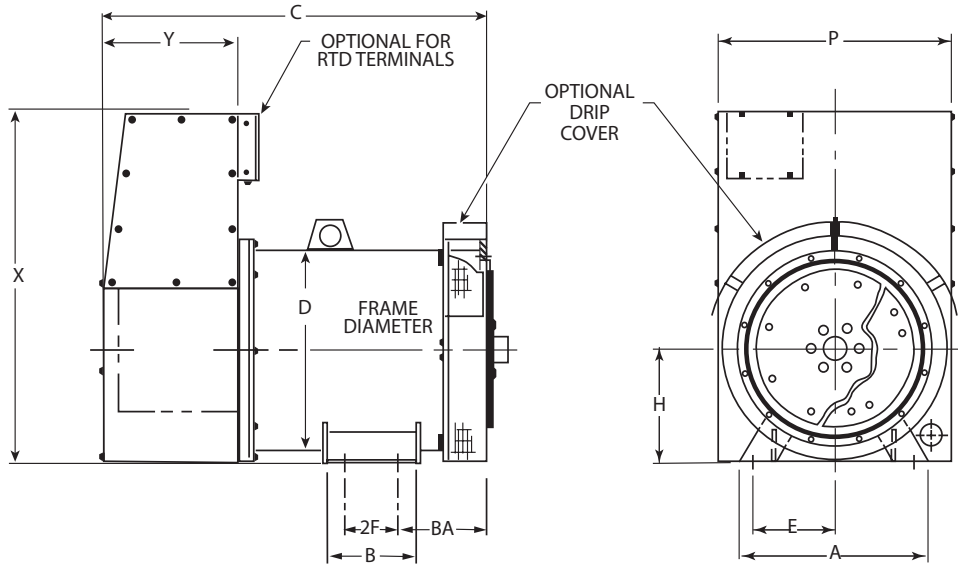

Frame Size	A	B	BA	C	D	E	2F	H	P	X	Y
431	21.00 (533)	10.00 (254)	10.00 (254)	38.40 (975)	22.64 (575)	9.00 (229)	6.00 (152)	13.00 (330)	26.51 (673)	39.77 (1010)	15.21 (386)
432	21.00 (533)	10.00 (254)	10.00 (254)	43.40 (1102)	22.64 (575)	9.00 (229)	6.00 (152)	13.00 (330)	26.51 (673)	39.77 (1010)	15.21 (386)
433	21.00 (533)	15.00 (381)	10.00 (254)	49.40 (1255)	22.64 (575)	9.00 (229)	11.00 (279)	13.00 (330)	26.51 (673)	39.77 (1010)	15.21 (386)
572	22.50 (572)	15.00 (381)	11.50 (292)	51.52 (1308)	27.64 (702)	10.00 (254)	11.00 (279)	15.50 (394)	30.77 (782)	42.64 (1083)	17.21 (437)
573	22.50 (572)	24.00 (610)	11.50 (292)	58.02 (1474)	27.64 (702)	10.00 (254)	20.00 (508)	15.50 (394)	30.77 (782)	42.64 (1083)	17.21 (437)
574	22.50 (572)	24.00 (610)	11.50 (292)	65.02 (1651)	27.64 (702)	10.00 (254)	20.00 (508)	15.50 (394)	30.77 (782)	42.64 (1083)	17.21 (437)
575	22.50 (572)	24.00 (610)	11.50 (292)	69.27 (1759)	27.64 (702)	10.00 (254)	20.00 (508)	15.50 (394)	30.77 (782)	42.64 (1083)	19.21 (488)
740	33.00 (838)	27.00 (686)	12.00 (305)	71.37 (1813)	27.64 (702)	15.00 (381)	23.00 (584)	19.00 (483)	30.77 (782)	51.45 (1307)	19.21 (488)
741	33.00 (838)	27.00 (686)	12.00 (305)	65.81 (1672)	34.24 (870)	15.00 (381)	23.00 (584)	19.00 (483)	38.08 (967)	51.45 (1307)	21.24 (539)
742	33.00 (838)	27.00 (686)	12.00 (305)	72.81 (1849)	34.24 (870)	15.00 (381)	23.00 (584)	19.00 (483)	38.08 (967)	51.45 (1307)	21.24 (539)
743	33.00 (838)	41.00 (1041)	12.00 (305)	79.31 (2014)	34.24 (870)	15.00 (381)	37.00 (940)	19.00 (483)	38.08 (967)	51.45 (1307)	21.24 (539)
744	33.00 (838)	41.00 (1041)	12.00 (305)	85.81 (2180)	34.24 (870)	15.00 (381)	37.00 (940)	19.00 (483)	38.08 (967)	51.45 (1307)	21.24 (539)
764	33.00 (838)	41.00 (1041)	14.52 (369)	87.32 (2218)	34.24 (870)	15.00 (381)	37.00 (940)	19.00 (483)	38.27 (972)	51.57 (1310)	22.76 (578)

- Notes:
- Connection boxes shown are furnished as standard product. Consult factory for Optional connection boxes.
 - Must have a minimum clearance of 6 inches for air flow into the conduit box. However, additional clearance may be required for servicing.

Dimensions & Weights

in inches and (millimeters)

ALL DIMENSIONS ARE APPROXIMATE: Contact factory for full dimensional data

Net weight in pounds

Model	Weight (lbs)
573FSL4202	3400
573FSL4402	3400
574FSL4204	3650
574FSL4404	3650
742FSL4208	5900
742FSL4408	5900
743FSL4210	6500
743FSL4212	6900
743FSL4410	6500
743FSL4412	6900
744FSL4060	7300
744FSL4062	8300
744FSL4214	7300
744FSL4216	8300
744FSL4218	8900
744FSL4414	8300
573FSM4304	2890
573FSM4306	3030
573FSM4326	2890
573FSM4328	3030
573FSM4352	2890
573FSM4354	3030
574FSM4308	3530
574FSM4310	4050
574FSM4330	3530
574FSM4356	3530
574FSM4358	4050
574FSM4380	3650
741FSM4314	5300
741FSM4334	5300
741FSM4360	5300
741FSM4382	5600
742FSM4316	6100
742FSM4318	6900
742FSM4336	6100
742FSM4338	6900
742FSM4364	6100
742FSM4366	6900
742FSM4384	6100
742FSM4386	6500
742FSM4388	6900

Model	Weight (lbs)
743FSM4320	7500
743FSM4322	8200
743FSM4340	7500
743FSM4342	8200
743FSM4368	7500
743FSM4370	8200
743FSM4390	7500
743FSM4392	8200
744FSM4344	9300
744FSM4345	9340
744FSM4374	9346
744FSM4375	9340
744FSM4394	9300
744FSM4395	9300
764FSM4347	9540
764FSM4377	9540
764FSM4397	9540
573FSS4224	3400
574FSS4226	3650
743FSS4232	6500
743FSS4234	6900
744FSS4236	7300
744FSS4238	8300
744FSS4240	8600
572RSL0120	2050
572RSL0122	2204
572RSL0124	2502
572RSL4160	2730
572RSL4162	2840
572RSL6425	2730
572RSL6427	2840
572RSL6429	3050
572RSL6431	3110
573RSL0126	2976
573RSL0128	3417
573RSL4164	3400
573RSL6433	3400
573RSL6435	3620
574RSL0130	4144
574RSL6437	4080
574RSL6438	4240

Model	Weight (lbs)
574RSL4038	4240
574RSL4166	4080
574RSL4168	4240
575RSL4044	5000
740RSL4046	5200
741RSL4044	5490
741RSL4170	5490
742RSL0132	6488
742RSL0134	7438
742RSL4048	6300
742RSL4050	7230
742RSL4172	6300
742RSL4286	5950
743RSL0136	8708
743RSL4052	7800
743RSL4174	7800
744RSL0138	9340
744RSL4054	8600
744RSL4056	9740
744RSL4057	9740
744RSL4176	8600
764RSL4063	9937
764RSL4177	8797
572RSS0140	2080
572RSS0142	2230
572RSS0144	2500
572RSS4270	2840
572RSS4272	3110
573RSS0146	3026
573RSS0148	3448
574RSS0150	4180
742RSS0152	6542
742RSS0154	7480
743RSS0156	8760
743RSS4288	7230
743RSS4290	7800
744RSS0158	9386
744RSS4292	8600
744RSS4293	9740
764RSS4295	9937

DIMENSIONS | TECHNICAL

Dimensions & Weights

in inches and (millimeters)

ALL DIMENSIONS ARE APPROXIMATE: Contact factory for full dimensional data

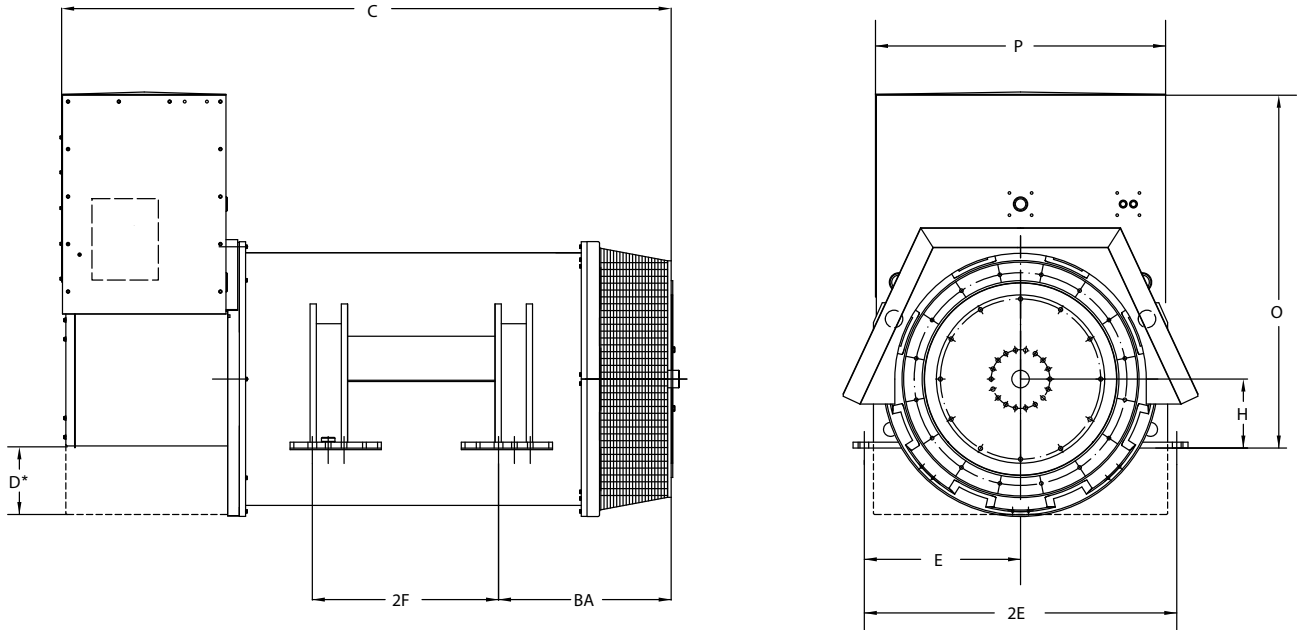

Frame Size	C	BA	2F	E	2E	H	O	P	D*
861	96.0 (2438)	27.2 (691)	29.3 (745)	24.6 (625)	49.2 (1250)	10.9 (276)	56.1 (1425)	45.7 (1161)	29.33 (2661)
862	102.7 (2608)	27.2 (691)	34.3 (870)	24.6 (625)	49.2 (1250)	10.9 (276)	56.1 (1425)	45.7 (1161)	29.33 (2661)
863	108.9 (2766)	27.2 (691)	39.4 (1000)	24.6 (625)	49.2 (1250)	10.9 (276)	56.1 (1425)	45.7 (1161)	29.33 (2661)

D* LOW VOLTAGE ONLY

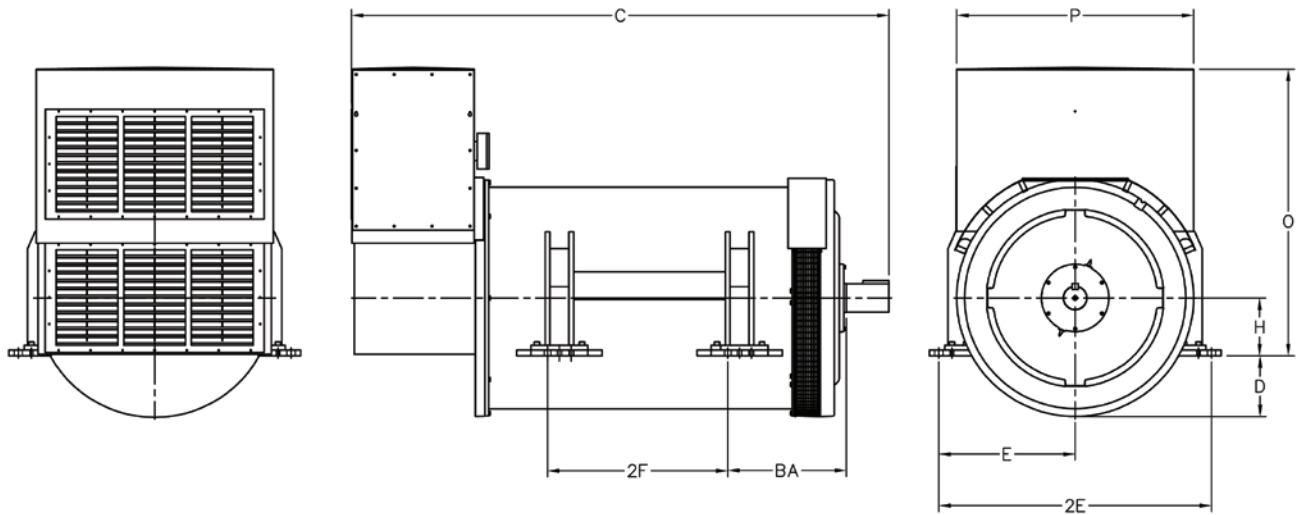

Frame Size	BA	C	D	E	2E	2F	H	O	P
1020	25.03 (636)	107.89 (2740)	12.78 (325)	28.75 (730)	57.50 (1460)	31.00 (787)	12.25 (311)	60.47 (1536)	50.00 (1270)
1030	25.03 (636)	113.36 (2879)	12.78 (325)	28.75 (730)	57.50 (1460)	38.00 (965)	12.25 (311)	60.47 (1536)	50.00 (1270)

- Notes:
- Connection boxes shown are furnished as standard product. Consult factory for Optional connection boxes.
 - Must have a minimum clearance of 6 inches for air flow into the conduit box. However, additional clearance may be required for servicing.

Dimensions & Weights

in inches and (millimeters)

ALL DIMENSIONS ARE APPROXIMATE: Contact factory for full dimensional data

Net Weight in pounds

Model	Weight (lbs)
861FSH86172	10582
862FSH86174	11784
862FSH86176	12897
862RSL86006	13780
863FSL86056	14500
863FSH86178	13173
863FSH86180	14947
863FSH86182	15650
1020FDL1100	15000
1020FDL1102	15900
1020FDL1104	16300
1020FDL1106	17000
1020FDL1108	17400
1020RDL1109	16800
1020RDL1111	17200
1020FDH1200	13200
1020FDH1202	13700

Model	Weight (lbs)
1020FDH1204	14500
1020FDH1240	14000
1020FDH1242	14200
1020FDH1244	14475
1020FDH1246	14900
1020FDH1248	15500
1020FDM1182	15700
1020FDM1184	15900
1020FDM5320	14500
1020FDM5322	15900
1020FDM5324	16800
1020FDM5332	15900
1020FDM5334	16800
1020FDM5336	17900
1020FDS1120	15430
1020FDS1120	15835
1020FDS1124	17850

Model	Weight (lbs)
1030FDL1110	20000
1030FDH1206	16600
1030FDH1208	16800
1030FDH1250	16200
1030FDH1252	17700
1030FDH1254	18000
1030FDM1186	16900
1030FDM1188	17100
1030FDM1190	17900
1030FDM1192	18100
1030FDM5326	17900
1030FDS1126	19875
1030FDS1128	20000

Net Weight in pounds

Base Model	Weight (lbs)
1020FDH1440	14000
1020FDH1442	14200
1020FDH1444	14475
1020FDH1446	14900
1020FDH1448	15500
1030FDH1452	17700
1030FDH1454	18000
1020FDL1300	15000
1020FDL1302	15900
1020FDL1306	17000
1020FDL1308	17400
1030FDL1310	20000

Base Model	Weight (lbs)
861FSH14152	10582
862FSH14154	11784
862FSH14156	12897
863FSH14158	13173
863FSH14160	14947
863FSL13056	14500
743RSL1352	7800
744RSL1354	8600
744RSL1356	9740
764RSL1364	9937
862RSL13006	13780
1020RDL1309	16800
1020RDL1311	17200

DATAMAX® Generators

Dimensions & Weights

LIMA® MAC Irrigator

in inches and (millimeters)

ALL DIMENSIONS ARE APPROXIMATE: Contact factory for full dimensional data

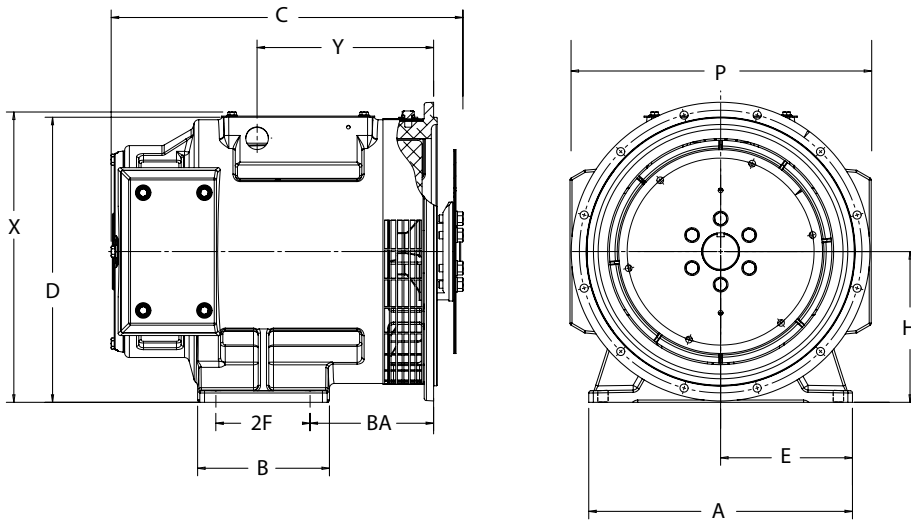

Base Model	Weight (lbs)
260MSL1054	203
260MSL1055	251
260MSL1056	254

260 LIMA MAC Generator

Frame Size	A	B	BA [Ⓢ]	C [Ⓢ]	D	E	2F	H	P	X	Y
260	14.00 (356)	7.00 (178)	6.56 (167)	18.49 (470)	15.14 (384)	7.00 (178)	5.00 (127)	8.00 (203)	15.99 (406)	15.41 (391)	9.37 (238)

Notes: [Ⓢ] This dimension will vary dependent upon adaption used.

Dimensions & Weights

in inches and (millimeters)

ALL DIMENSIONS ARE APPROXIMATE: Contact factory for full dimensional data.

Pancake (AVR and Capacitor)

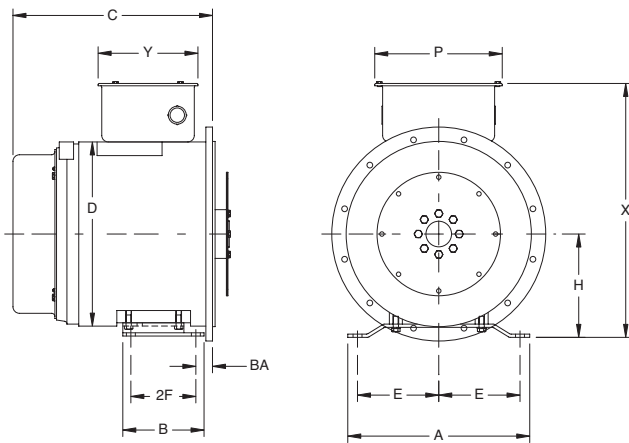

AVR Ratings 331-334 Frames

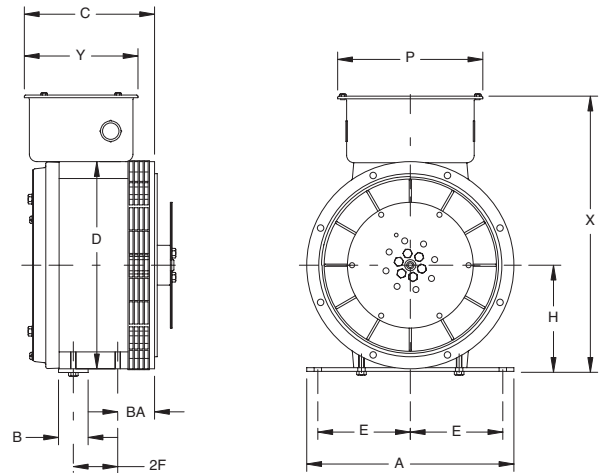

Capacitor Ratings 201 Frames

Type	Frame Size	A	B	C	D	E	H	P	X	Y	BA	2F
Pancake AVR	331	14.0 (356)	6.25 (159)	10.6 (269)	14.0 (356)	6.25 (159)	7.95 (202)	11.3 (287)	19.0 (483)	5.8 (147)	1.17 (30)	5.0 (127)
	332	14.0 (356)	6.25 (159)	11.6 (295)	14.0 (356)	6.25 (159)	7.95 (202)	11.3 (287)	19.0 (483)	5.8 (147)	1.17 (30)	5.0 (127)
	333	14.0 (356)	6.25 (159)	14.0 (356)	14.0 (356)	6.25 (159)	7.95 (202)	11.3 (287)	19.0 (483)	5.8 (147)	1.28 (33)	5.0 (127)
	334	14.0 (356)	6.25 (159)	14.4 (366)	14.0 (356)	6.25 (159)	7.95 (202)	11.3 (287)	19.0 (483)	5.8 (147)	1.28 (33)	5.0 (127)
Pancake Capacitor	201CSA5411	8.17 (208)	4.0 (102)	9.72 (247)	10.75 (273)	3.3 (84)	6.92 (176)	8.62 (219)	15.69 (399)	4.15 (113)	2.5 (63.5)	3.0 (76)
	201CSA5420	8.17 (208)	4.0 (102)	10.71 (272)	10.75 (273)	3.3 (84)	6.92 (176)	8.62 (219)	15.69 (399)	4.15 (113)	2.5 (63.5)	3.0 (76)
	201CSA5422	8.17 (208)	4.0 (102)	10.71 (272)	10.75 (273)	3.3 (84)	6.92 (176)	8.62 (219)	15.69 (399)	4.15 (113)	2.5 (63.5)	3.0 (76)

Pancake AVR

Base model	Weight (lbs.)
331	125
332	143
333	192
334	214

Pancake Capacitor

Base model	Weight (lbs.)
201CSA5411	110
201CSA5420	127
201CSA5422	127

DIMENSIONS | TECHNICAL

Technical Data

Environmental and Special Considerations

Once the size of the generator has been determined, it is important to review the environmental and special conditions which may affect the life of the generator. Some of the most common conditions which may require special attention are outlined below.

ALTITUDE / AMBIENT - For applications over 3300 feet elevation or where the temperature of the ventilating air to the generator exceeds 40°C (104°F), derating of the generator will be necessary. To determine the derating, use the chart below by moving vertically on the specified altitude to the horizontal line that matches the required ambient temperature, then select the derating required.

Note: When a NEMA®* class of insulation is specified, additional derating of kW available may be necessary. Per NEMA MG 1-2011, Part 32.6: For successful operation of generators in ambient temperatures higher than 40°C, the temperature rises... shall be reduced by the number of degrees that the ambient temperature exceeds 40°C.

ABRASIVE DUSTS - When it is possible that airborne abrasive dusts will be introduced to the generator with the ventilating air, additional protection is recommended. Dirt, sand, volcanic ash, gravel, rock dust, etc. are typical of this type of application. Although the generator windings are protected against abrasive environments, severe conditions may warrant protection by means of baffles, housings and filters, or other suitable means. Refer to factory for recommendations.

HIGH HUMIDITY AND TROPICAL CLIMATE - In moist or humid areas such as the Tropics, coastal areas, and all marine service, additional protection is recommended. Although the standard windings are humidity and moisture resistant, space heaters are required for these environments.

OUTDOOR APPLICATION - All generators for outdoor application must be protected from the elements by sheet metal housings with the proper openings for ventilation. This protection should be designed to prevent the direct contact of wind driven rain, snow, or dust with the generator. Space heaters are recommended depending on location and type of service. Refer to factory for recommendations on enclosure requirements.

NON-LINEAR LOADING - Solid state electronic control devices which utilize thyristors or SCR firing circuits (such as variable frequency induction motor controls, precision motor speed controls, no-break powered battery chargers, etc.) can introduce high frequency harmonics which adversely affect the normal waveform of the generator. This creates additional heat in the generator stator and rotor and can cause overheating. These devices can and do present problems to non-utility power generating equipment or any limited power bus system. The problems which can occur are not limited to the generator itself, but can affect the solid state control device, the equipment it controls, other associated loads, monitoring devices or a number of combinations over the entire system.

It is important that the control manufacturer, the generator manufacturer, and the systems engineer work together to insure the proper selection of all components. Please refer to factory for application assistance.

ALTITUDE/AMBIENT RATING ADJUSTMENT

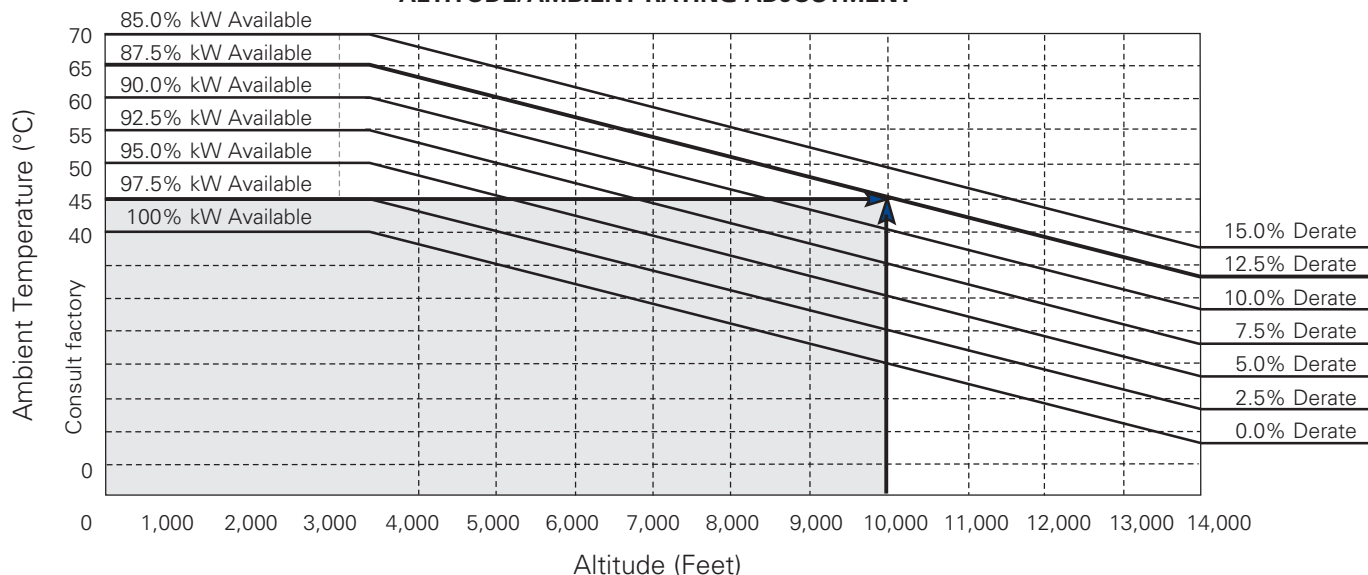

Example:

Elevation: 10,000 feet
 Ambient: 45°C
 Required Derate: 12.5%
 Catalog Rating x .875

Example:

NEMA B class of insulation is specified in a 45°C ambient.
 Maximum allowable temperature rise is reduced from 80°C to 75°C.

*NEMA is a trademark or trade name of National Electrical Manufacturers Association and is not owned by or under the control of Marathon Electric LLC.

Technical Data

Connection Diagrams

SERIES

HIGH WYE

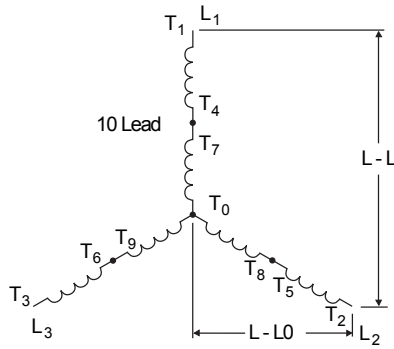
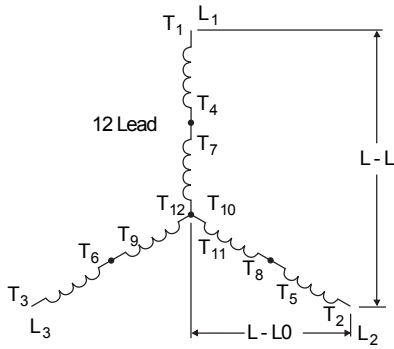

Voltage		
HZ	L-L	L-L0
60	380	219
	416	240
	440	254
	460	266
	480	277
	600	346
50	380	219
	400	231
	415	240
	440	254

PARALLEL

LOW WYE

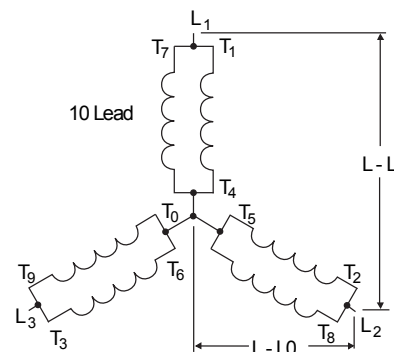
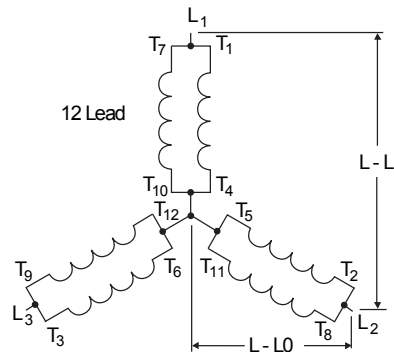

Voltage		
HZ	L-L	L-L0
60	190	110
	208	120
	220	127
	230	133
	240	139
	240	139
50	190	110
	200	115
	208	120
	220	127

WYE

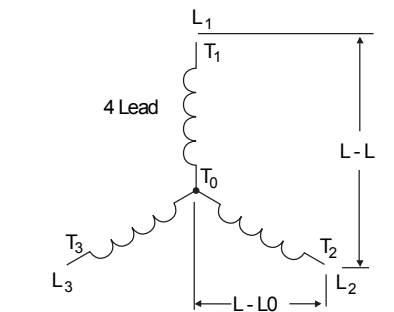
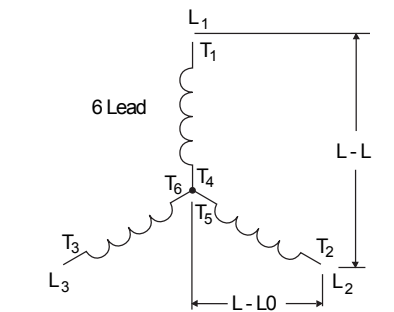

Voltage		
HZ	L-L	L-L0
60	380	219
	480	277
	600	346
	2400	1386
	3300	1905
	4160	2402
	6600	3811
	13800	7967
50	380	219
	400	231
	415	240
	3300	1905
	6600	3811
11000	6351	

SERIES

HIGH DELTA

Voltage		
HZ	L-L	L-L0
60*	240	120
50	200	100
	220	110
	240	120

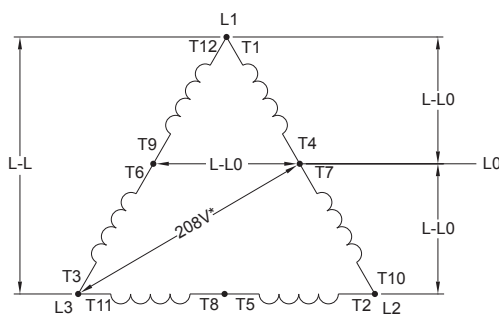

PARALLEL

LOW DELTA

Voltage	
HZ	L-L
60	110
	120
50	100
	110

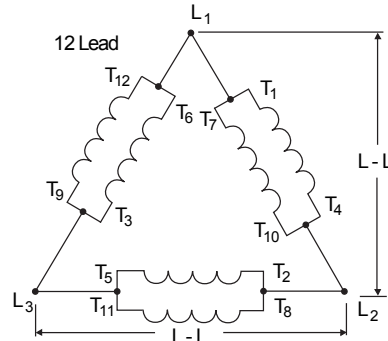

Technical Data

Connection Diagrams

DELTA

Voltage	
HZ	L-L
60	2402 7967
50	1905 6351

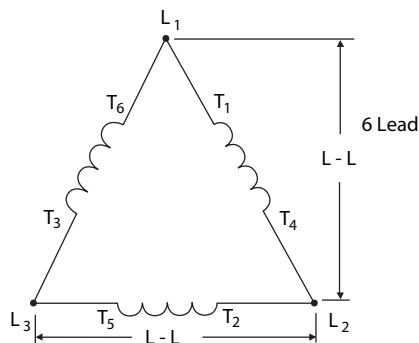

DOUBLE DELTA

Single Phase Connection ①

Voltage		
HZ	L-L	L-L0
60	200 220 240	100 110 120
50	220	110

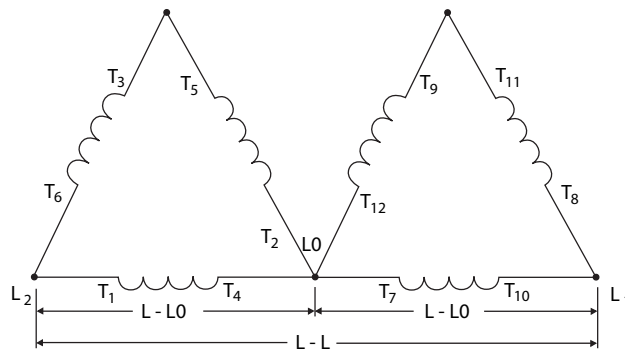

PARALLEL

LOW ZIGZAG

Single Phase Connection ①

Voltage		
HZ	L-L	L-L0
60	200 220 240	100 110 120
50	220	110

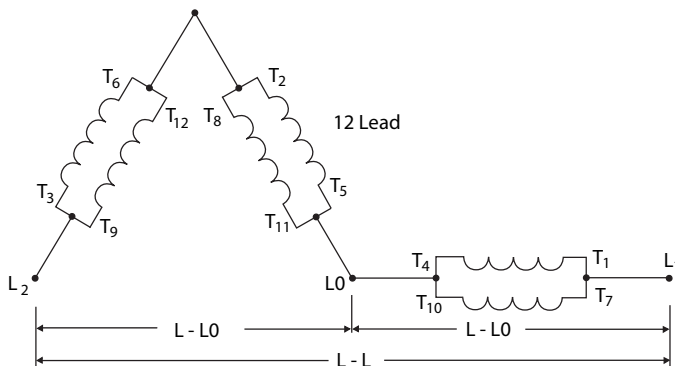

SERIES

HIGH ZIGZAG

Single Phase Connection ①

Voltage		
HZ	L-L	L-L0
60	480	240
50	440	220

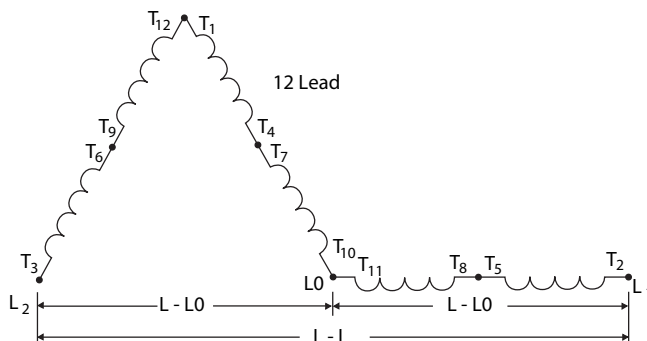

① Single phase kW/kVA ratings are approximately equal to 50% of the generator's three-phase ratings.

Technical Data

Automatic Voltage Regulator Features

Feature	STANDARD MODELS				SPECIAL (OPTIONAL) MODELS	
	SE350E	SE350EL	DVR®2400	PM500	DVR®2500	AVC63-12
Analog Input	No	No	Yes	Yes	Yes	Yes
Min. Exciter Field Resistance Ohms	15.0	15.0	18.0	15.0	18.0	5.25
Voltage Regulation No Load to Full Load	1.0%	1.0%	0.25%	0.25%	0.25%	0.5%
Underspeed Protection	Yes	Yes	Yes	Yes	Yes	Yes
Overexcitation Protection	Yes	Yes	Yes	Yes	Yes	Yes
EMI / RFI Filtering ①	Yes	Yes	Yes	Yes	Yes	Yes
Unit Mounted Voltage Adjust	Std.	Std.	Std.	Std.	Std.	Std.
Overvoltage Protection	No	No	Std.	Std.	Std.	No
Encapsulated	Yes	Yes	Yes	Yes	Yes	Yes
Paralleling ③	Opt④	Opt④	Std.	Std.	Std.	Std.
Line Drop Compensation	No	No	No	No	No	Yes
VAR/PF Controller	No	No	Yes	No	Yes	Opt⑤
Input Power - VAC	240	120 or 240②	PMG	PMG	PMG	120
Cont. Output - ADC	3.5	3.5	4.0	5.0	4.0	12.0
Cont. Output - VDC	63	63	100	85	100	63
Sensing Input - VAC	190-240	85-120 190-240②	100-600	175-280 330-515 420-660	100-600	Option B: 180-264
Sensed Voltage	Average	Average	RMS	RMS	RMS	Average
Sensing Frequency (Hz)	50/60	50/60	50/60	50/60	50/60	Option 1: 50/60 2: 400
Generator Current Limiting Protection	No	No	No	No	No	No
AVR Condition LEDs	No	No	Yes	No	Yes	No
3 Phase Sensing	No	No	Yes	Yes	Yes	Yes
1 Phase Sensing	Yes	Yes	Yes	Yes	Yes	Yes
Loss of Sensing Protection	Yes ⑥	Yes ⑥	Yes	No	Yes	No
300% Short Circuit Protection	No	No	Yes	Yes	Yes	No

① With regulator mounted in generator conduit box.

② Depends on switch position.

③ Requires the addition of a paralleling current transformer.

④ Requires the addition of a paralleling module along with a paralleling current transformer.

⑤ Requires the addition of VAR/PF Module.

⑥ Protection is inherent. Sensing and power input share the same two leads.

A loss of sensing (open in the sensing circuit) results in an open in the input power circuit, and the regulator will shut down.

General Formulas

Generator Formulas ①

Desired Data	Single Phase	Three Phase
Kilo Volt Amperes (kVA)	$\frac{\text{Volts} \times \text{Amps}}{1000}$ or $\frac{\text{kW}}{\text{P.F.}}$	$\frac{\sqrt{3} \times \text{Volts} \times \text{Amps}}{1000}$ or $\frac{\text{kW}}{\text{P.F.}}$
Kilowatts (kW)	$\frac{\text{Volts} \times \text{Amps} \times \text{P.F.}}{1000}$ or $\text{kVA} \times \text{P.F.}$	$\frac{\sqrt{3} \times \text{Volts} \times \text{Amps} \times \text{P.F.}}{1000}$ or $\text{kVA} \times \text{P.F.}$
Power Factor (P.F.)	$\frac{\text{kW}}{\text{kVA}}$	$\frac{\text{kW}}{\text{kVA}}$
Amperes When kW is Known	$\frac{\text{kW} \times 1000}{\text{Volts} \times \text{P.F.}}$	$\frac{\text{kW} \times 1000}{\sqrt{3} \times \text{Volts} \times \text{P.F.}}$
Amperes When kVA is Known	$\frac{\text{kVA} \times 1000}{\text{Volts}}$	$\frac{\text{kVA} \times 1000}{\sqrt{3} \times \text{Volts}}$
Minimum HP Required for Prime Mover	$\frac{\text{kW}}{\text{Alternator Efficiency} \times 0.746}$	
Frequency (Hz)	$\frac{\text{Number of Poles} \times \text{RPM}}{120}$	
Revolutions Per Minute (RPM)	$\frac{\text{Hz} \times 120}{\text{Number of Poles}}$	
Number of Poles	$\frac{\text{Hz} \times 120}{\text{RPM}}$	

① P.F. = Power Factor

Agency Information

Matrix of Generator and AVR Approvals & Markings

Pancake	CE**	CSA**	UL**
201 Capacitor	N	Y	N
332-334	N	Y	N

MAGNAMAX® Generator	CE	CSA	UL
431-433 MV	N	Y	N
572-575 MV	N	Y	N
741-764 MV	N	Y	N

MAGNAMAX® Generator	CE	CSA	UL
572-575 LV	Y	Y	Y
740-764 LV	Y	Y	Y

MAGNAPLUS® Generator	CE	CSA	UL
281-287	Y	Y	Y
361-364	Y	Y	Y
431-433	Y	Y	Y

MAGNAPOWER® Generator	CE	CSA	UL
1020 - 1030 LV	Y	Y	Y
1020 - 1040 MV	N	Y	N
1020 - 1040 HV	N	Y	N

LIMA®MAC Generator	CE	CSA	UL
260	Y	N	N

AVR	CE	CSA	UL Certified for Canada Component	UL Recognized
SE350E Regulator	N	Y	N	Y
SE350EL Regulator	Y	N	Y	Y
PM500 Regulator	Y	N	Y	Y
AVC63-12 B1 & B2 Regulator	Y	Y	N	Y
DVR®2400 Regulator	Y	Y	N	Y
DVR®2500 Regulator	Y	Y	N	Y



UL Listing Mark - MAGNAMAX® and MAGNAPLUS® units complete with regulator and conduit box and rated at 600 volts max. Our UL Certification file number is E218422. Go to www.ul.com and select the link titled "Find a product certification" and then register to access their Product iQ online directory or log on if already registered; then enter E218422 in the search box and click on JZGZ.E218422 for a complete list of certified products.



UL Listing Mark for the U.S. and Canada – Applies to certain MagnaPLUS units in frame sizes 283, 284, 285, and 286 that are specifically Listed for Class 1, Division 2 hazardous locations. Our UL certification file number is E12044. Go to www.ul.com and select the link titled "Find a product certification" and then register to access their Product iQ online directory or log on if already registered; then enter E12044 in the search box and click on PSPO.E218422 for a complete list of certified products.



UL Recognized Component Mark - 1) MAGNAMAX and MAGNAPLUS units but without conduit box and/or regulator. 2) MAGNAPOWER® units with or without regulator This applies to units rated 600 V or less. Our UL Certification File number is E218422. Go to www.ul.com and select the link titled "Find a product certification" and then register to access their Product iQ online directory or log on if already registered; then enter E218422 in the file number search box and click on JZGZ.E218422 for a complete list of certified products. 3) Voltage regulators – same search details but using file number E222903; click on FTMP2.E222903 for a complete list of certified products.



CSA Certification Mark - Applies to majority of MAGNAPOWER, MAGNAMAX and MAGNAPLUS units. Our CSA Certification File number is LR2025 for MAGNAMAX and MAGNAPOWER units and LR9401 for MagnaPlus units. Go to www.csagroup.org and select the Certified Product Listing link and enter either 002025 or 009401 in the file number search box, Class 4211-01 covers generators, Class 3211-06 covers voltage regulators.



CSA Certification Mark for Canada and the US - Applies to certain MAGNAMAX, MAGNAPLUS, and MAGNAPOWER units that are specifically Certified for Class 1, Division 2 hazardous locations. Our CSA Certification File number is LR21839. Go to www.csagroup.org and select the Certified Product Listing link and enter 021839 in the file number search box and select the link under CSA Class No. 4228-81.



ATEX** symbol - Signifies compliance to the European ATEX Directive which applies to equipment for use in potentially explosive atmospheres. Special construction; available for Zone 2 only. Applies to 282-285 MAGNAPLUS® and 431-744 MAGNAMAX® generators. Third party certification is through CSA Group Netherlands B.V., generators are nameplated "Ex ec" (Increased Safety protection method) and "IIC" (covers Gas Groups IIA, IIB, IIC) and "T3" (Operating Temperature Code (T3= surface temperatures less than 200°C).



CE Marking - An acronym for the French "Conformite Europeene"; this marking is required on certain equipment imported to European Union countries based on individual Directives (Laws). MAGNAMAX, MAGNAPLUS, and LIMA®MAC units complete in every aspect of construction, and rated 1000 volts or less, carry the CE marking, based on the Low Voltage Directive.

*The following trademarks are not owned by or under the control of Marathon Electric LLC: ATEX and CE are trademark of European Unions; CSA is a tradename of CSA Group; UL is a trademark or trade name of Underwriters Laboratories.

IMPORTANT INFORMATION

Please Read Carefully

This catalog is not intended to provide operational instructions. Appropriate Marathon® generator instructions provided with the generator and precautions attached to the generator should be read carefully prior to installation, operations and/or maintenance of the equipment. Injury to personnel or generator failure may be caused by improper installation, maintenance or operation.

The following **WARNING!** and **CAUTION!** information is supplied for your protection and to provide you with many years of trouble free and safe operation of your Marathon generator.

"WARNING" indicates a hazardous situation that, if not avoided, could result in death or serious injury and "CAUTION" indicates a hazardous situation that, if not avoided, could result in minor or moderate injury.

⚠ WARNING

- Buyer shall be solely responsible for determining the adequacy of the product for any and all uses to which Buyer shall apply the product. The application by Buyer shall not be subject to any implied warranty of fitness for a particular purpose.
- For safety, Buyer or User should provide protective guards over all shaft extensions and any moving apparatus mounted thereon. The User is responsible for checking all applicable safety codes in his area and providing suitable guards. Failure to do so may result in bodily injury and/or damage to equipment.
- Hot oil can cause severe burns. Use extreme care when removing lubrication plugs.
- Disconnect power and lock out drive equipment before working on a generator.
- Always keep hands and clothing away from moving parts.
- The lifting eyes on the generator are not to be used to lift the entire generator set. Only the generator may be safely lifted by the lifting eyes. Do not use the conduit box for lifting or support of the generator.
- Install and ground the generator per local and national codes.
- Discharge all capacitors before servicing the generator.
- Misapplication of a generator in a hazardous environment can cause fire or an explosion and result in serious injury.
- Never attempt to measure the temperature rise of a generator by touch. Temperature rise must be measured by thermometer, resistance, imbedded detector or thermocouple.
- Operation of a generator at higher than its nameplate ratings may result in fire, damage to equipment or serious injury to personnel.

⚠ CAUTION

- Do not apply any force to the generator fan when rotating the generator rotor.
- Mounting bolts should be routinely checked to ensure that the unit is firmly anchored for proper operation.
- Consult qualified personnel with questions. All electrical repairs must be performed by trained and qualified personnel only.
- Generators should not be operated faster than their rated speed.
- For inverter applications, follow the inverter manufacturer's installation guidelines.
- Make sure the generator is properly secured and aligned before operation.
- When installing the generator, insure that loose parts or tools do not fall inside the generator.
- When connecting the generator, be sure to follow the correct wiring diagram for the desired voltage. Ensure that the voltage regulator is connected per the wiring diagram.

Resale of Goods

In the event of the resale of any of the goods, in whatever form, Resellers/Buyers will include the following language in a conspicuous place and in a conspicuous manner in a written agreement covering such sale:

The manufacturer makes no warranty or representations, express or implied, by operation of law or otherwise, as to the merchantability or fitness for a particular purpose of the goods sold hereunder. Buyer acknowledges that it alone has determined that the goods purchased hereunder will suitably meet the requirements of their intended use. In no event will the manufacturer be liable for consequential, incidental or other damages. Even if the repair or replacement remedy shall be deemed to have failed of its essential purpose under Section 2-719 of the Uniform Commercial Code, the manufacturer shall have no liability to Buyer for consequential damages.

Resellers/Buyers agree to also include this entire document including the cautions and warnings above in a conspicuous place and in a conspicuous manner in writing to instruct users on the safe usage of the product.

This information should be read together with all other printed information supplied by Marathon Electric.

For more information contact:

Marathon Electric LLC,

100 E. Randolph St., Wausau, WI 54401

Phone: 715-675-3359

Freight Policy

All prices are quoted F.O.B. Marathon Electric LLC's factory or warehouse in Monterrey, Mexico; Wausau, WI; or Indianapolis, IN, dependent upon plant of manufacture.

Customers may use any one of the following methods for shipment:

- Pick up generators at our plant of manufacture on their own carrier
- Allow us to ship the generators freight collect
- Allow us to ship via our carriers with a percentage (%) adder applied to the net generator and accessory price.

Notes:

Notes:

North American Sales Territories Map

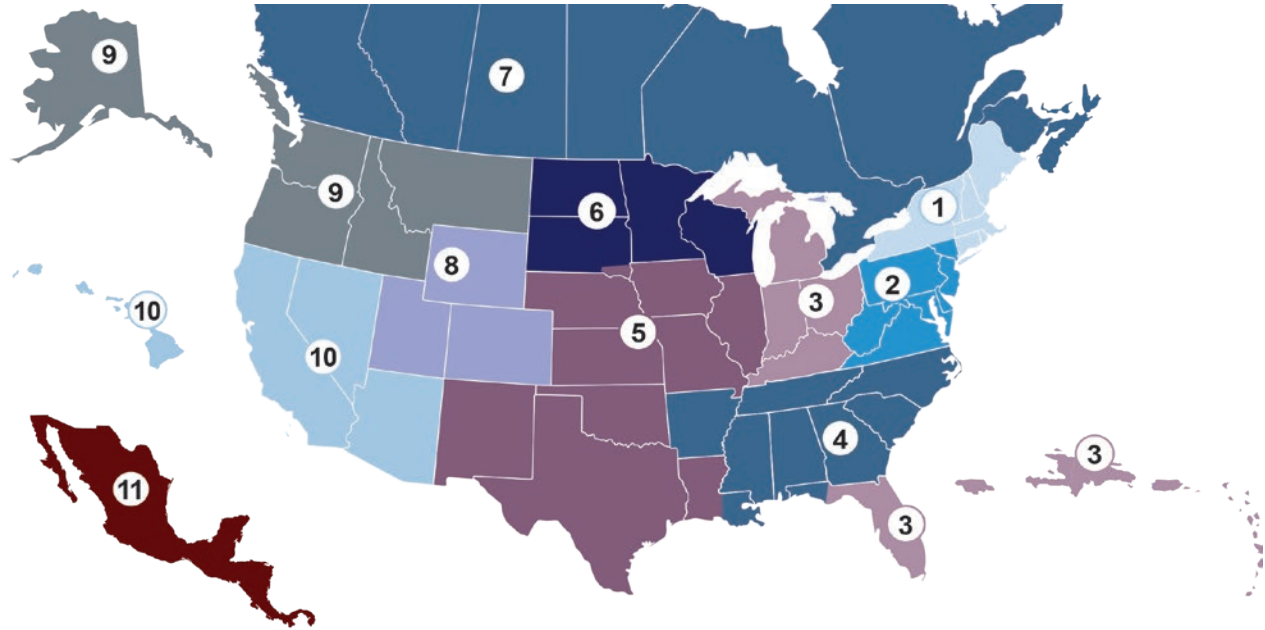

1 Goodall Industrial Equipment
 10 W Central St.
 Natick, MA 01760
 Phone: 508-651-2668
 E-mail: sales@goodallsales.com

2 FJ Toolan Inc.
 1 Revere Ct.
 Allentown, NJ 08501
 Phone: 609-259-0387
 E-mail: jeff@fjtoolan.com

3 Davidson Sales
 839 Bill France Blvd.
 Daytona Beach, FL 32117
 Phone: 386-274-2079
 E-mail: dsc@davidsonsales.com

4 Underwood Sales Co.
 2783 Longate Drive
 Memphis, TN 38132
 Phone: 901-332-4701
 Email: sales@uscinc.net

5 Power Source Midwest, Inc.
 18 Hawk Ridge Blvd., Ste. 120
 Lake St. Louis, MO 63367-1829
 Phone: 636-625-4771
 E-mail: sales@powersourcemidwest.com

6 Matt Taylor
 Sales Engineer
 P.O. Box 8003
 Wausau WI 54402-8003
 Phone: 715 660-0935
 E-mail: matthew.taylor@marathonelectric.com

7 Les Agences CMG Inc.
 135 Place Lussier
 Waterloo, QC
 J0E 2N0 CANADA
 Phone: 418 955-6136
 Email: maxime@agencescmg.com

8 David Dziekan
 National Sales Manager
 Frederick, CO
 Phone: 715-660-8390
 E-mail: david.dziekan@marathonelectric.com

9 Renosa Corporation
 PO Box 516
 Monroe, OR 97456
 Phone: 503 864-3952
 E-mail: dhammond@renosacorp.com

10 David Dziekan
 National Sales Manager
 Frederick, CO
 Phone: 715-660-8390
 E-mail: david.dziekan@marathonelectric.com

11 Juan Francisco III Illades Saucedo
 Ave. Benito Juárez 11 Int. 104
 Jardines de Santa Mónica
 54050 Tlalnepantla, Méx.
 Phone: 52-55-5374-3779
 Email: francisco@swgs.com.mx

INTERNATIONAL SALES TEAM

Vice President, Global Sales

Marcelo Oliveira
 Wausau, WI, USA
 United States
 Phone: [001] 404-640-7166
 Alt. Phone: [001] 404-513-0293
 Email: marcelo.oliveira@marathonelectric.com

When dialing from outside the country, omit the number in [].



Marathon Electric LLC

100 East Randolph Street
Wausau, WI 54402-8003
Phone: 715-675-3359
MarathonElectric.com

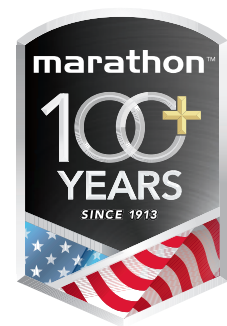

The proper selection and application of products and components, including assuring that the product is safe for its intended use, are the responsibility of the customer.

To view our Standard Terms and Conditions of Sale, please visit <https://www.marathonelectric.com> (which may redirect to other website locations based on product family).

The following trademarks or tradenames are owned by or under the control of a thirdparty and are not owned by Marathon Electric LLC: ATEX is a trademark of European Union; ABS is a trademark or tradename of American Bureau of Shipping; Bureau Veritas is a trademark or trade name of Bureau Veritas; CE is a trademark or tradename of European Unions; CSA is a tradename of CSA Group; Lloyd's Register is a tradename of Lloyd's Register Group Limited; NEMA is a trademark or trade name of National Electrical

"Marathon Generators" is not indicative of legal entity.

Marathon, DataMax, DVR, Lima, MagnaMax, MagnaPlus, MagnaPower, MagnaSelect and Mariner are trademarks of Marathon Electric LLC or one of its affiliated companies.

MG-CT24015E-R20 | SB0073E All rights reserved ©2017, 2022, 2023, 2024, 2025 Marathon Electric LLC